

# Radford.

## Installation Manual

Prepared by Dominic Casey for Coles

(29/09/2021)

Coles Itab Alphagate, 4 gate kit

## ITAB Alphagate 4 Gate Kit Installation & Commissioning Manual:

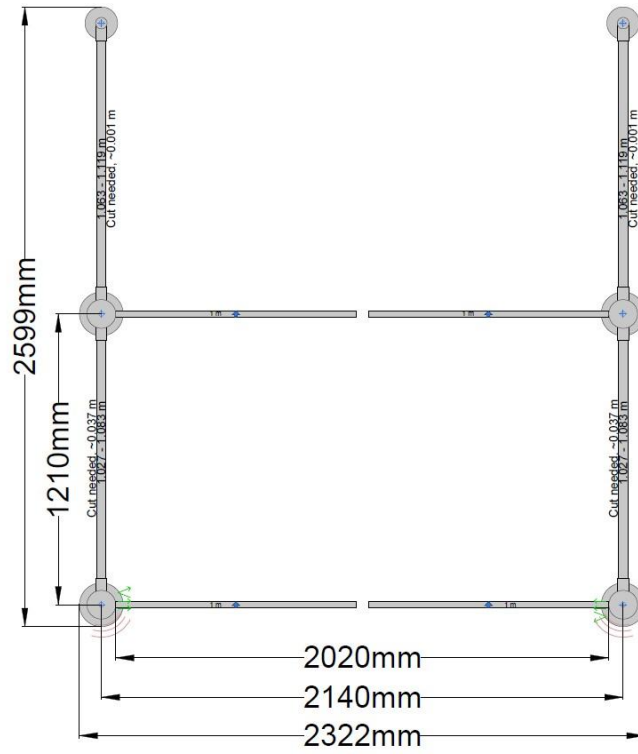

1. Unpack materials from crates & ensure all components are accounted for & fully intact.
2. Remove gate bollard front covers to reveal the electronics – front plate fixing screw bracket helps to locate the centre of the gate for floor marking.
3. Lay out the gates in situ & double-check the layout and “dimensional-correctness” with site foreman. Please ensure you have sufficient clearance for a 50mm safety gap between the individual gate-arm ends of no more 50mm – when satisfied with layout, carefully mark gate bollard fixing locations to be drilled.

Alpha fixing base plate drawing;

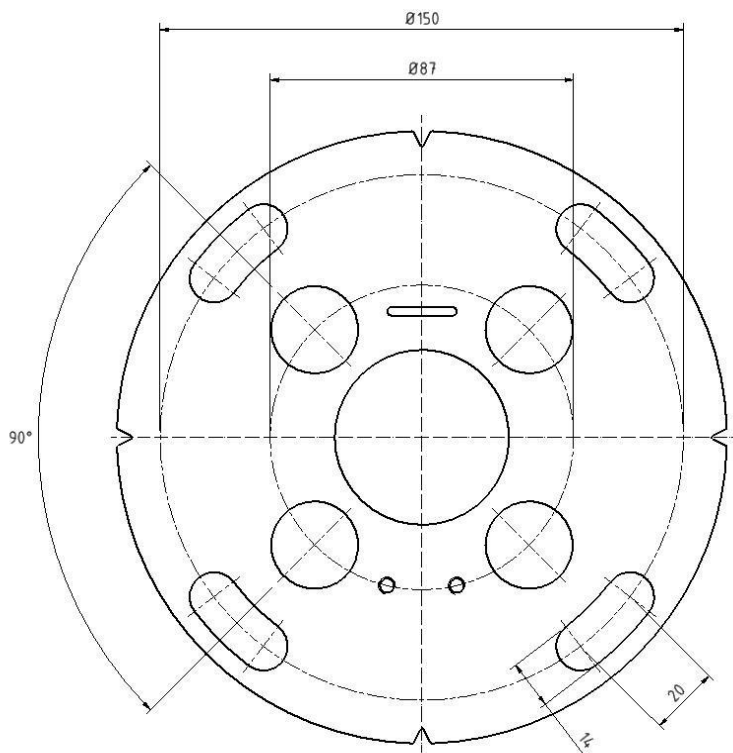

**Important:** before drilling, ensure all underground cables (power & data) are in situ and not likely to be damaged during the drilling process – see drawing below.

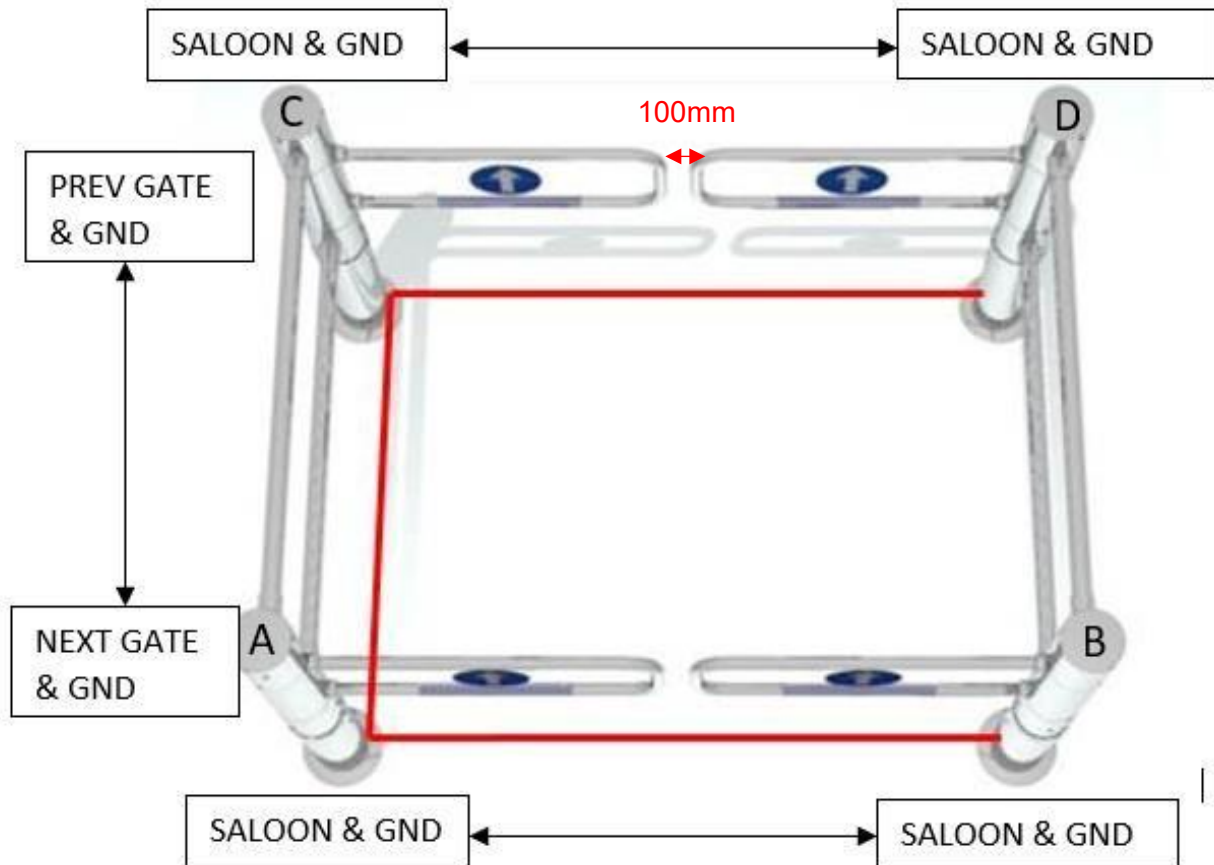

#### Synchronisation cable connections:

- **Front saloon-gate couple (A & B)** = connect to “saloon gate” & “ground” terminals at both ends – when triggered by their inbuilt (top mounted) radar sensors, these gates will now operate as one.
- **Second saloon-gate couple (C & D)** = connect to “saloon gate” & “ground” terminals at both ends – when triggered by (front- gate-mounted) photocell eyes, these gates will now operate as one.
- **Interconnecting data cable triggering of second saloon-gate couple:**  
Gate A = connect to “next gate” & “ground”  
Gate C = connect to “previous gate” & “ground”

(Note: each gate-bollard requires standard 230V power)

4. Bolt gate bollards firmly into the ground – carefully fit glass arms including post and rails as required.

## (Commissioning)

5. Dip switches:

Set up dip switches in each gate bollard, as per its installed position.

(upon entry to store, the gate on your left is considered a left-hand gate & the gate on your right is considered right-hand gate)

### Dip switch block settings:

- 1 = right position
- 2 = left or right position (as required)
- 3 = right position
- 4 = left position
- 5 = left position
- 6 = right position

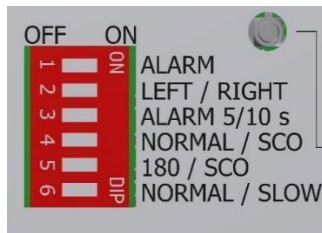

6. Set up Master & Slave function in each gate couple:

- Left-hand gate = set DELAY/SCO & SECURE/SCO potentiometers to maximum (righthand) position.
- Right hand gate = set DELAY/SCO potentiometer to full left and then approx. 25% of its full range to the right position.
- Once the gate synchronization cable is connected between both gates, the gate couple will then be controlled as one-unit and **all** adjustments made to the righthand controller will control both right and left-hand gates alike.

### **IMPORTANT NOTES:**

- Saloon-gate couple A & B operates independent to saloon-gate couple C & D.
- However, the PEC triggering sensors for saloon-gate couple C & D are physically mounted into the gate-bollards of saloon-gate couple A & B.

- The PEC sensors are hard-wired into the gate bollards A & B but only trigger the rear gate couple C & D.
- In a saloon-gate configuration, the right-hand gate is **ALWAYS** the Master.



Set potentiometer 1 & 3 to maximum on left-hand gate



## 7. Controller set up:

- Connect Synchronization cable to each front and rear saloon gate-couple.
- Remove the lid on top of each gate bollard and disconnect the radar electrical connector to (temporarily) render the radar out of circuit.
- Connect Synchronization cable to each front and rear gate-couple.
- Power up gates and press the test button (see figure 8.5 in Alphagate MKII manual) on the **front saloon-gate couple**.
- The gate couple (both left and right-hand gates) should open into the store, stopping in the 90-degree (fully open) position and remain open for a pre-set time before driving back to the fully closed position. To test, trigger the radar or PEC.
- The time-lapse (time gates remain fully open) for both gate bollards can be adjusted by the master (right-hand) gate DELAY/SCO potentiometer. Both gates should now be operating and closing at the same time.
- The recommended time delay (time-lapse) between the gates to reach the fully opened position and the time the gates start to drive back to the closed position is four (4) seconds.

- Adjust panic force potentiometer (break out function): wind to full left (off) position and then wind to the full right before setting to the approx. mid position.
- Repeat the above for the **second saloon-gate couple**.

## 8. Radar set up:

Both gates in the front saloon-gate couple are fitted with radar controllers to trigger the front gate couple as one unit.

- Connect the electrical connector back onto the radar unit.
- Adjust the mechanical radar bracket on each gate to position the radars pointing in the forward position (and slightly into the middle of the gate arms centre).
- Adjust the approach sensor (triggering distance potentiometer on the top of radar sensor) to the full left-hand (off) position.
- Then adjust in small-increments to the right until the gate is picking up a forward moving person at between 1.2 to 1.5 meters.
- Disconnect each radar electrical connector (one at a time) and test the sensor distance picks up a trigger signal from approx. 1.2 to 1.5 meters, opening both gates fully.
- Ensure electrical connectors are re-connected back to both radar units.
- Repeat this same process for the rear child safety sensor, keeping in mind that we do not want to have the sensor picking up people outside of the rails of the kit
- Ensure that all radar cabling is tidy and secured with a cable tie to prevent false triggering.

# Radford.

**Fig. 7** Area coverage  
"low sensitivity"

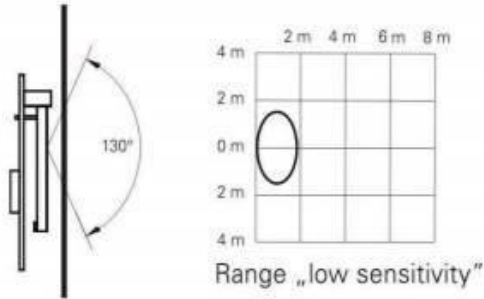

**Fig. 8** Area coverage  
from above

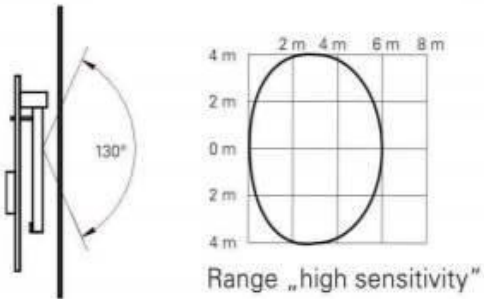

Potentiometer  
to adjust distance

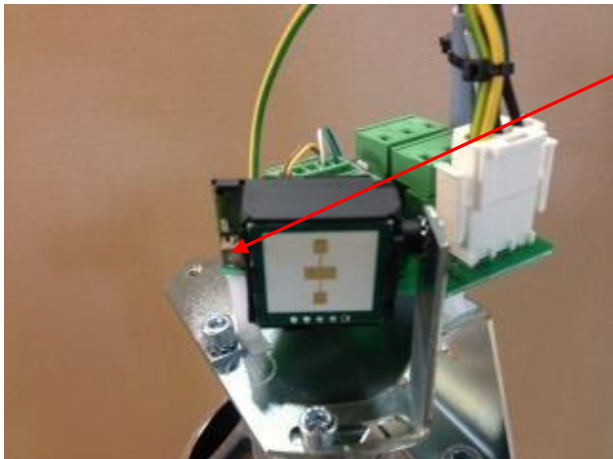

## 9. Set up PEC trigger for front gates:

- Connect Synchronization cable between front and rear gate couples (gates A & C)
- We recommend setting the right-hand PEC sensor only and unplugging the left-hand sensor if installed. Simply use the left-hand sensor as a reflector only. This will have no effect on gate operation and simplify the commissioning process.

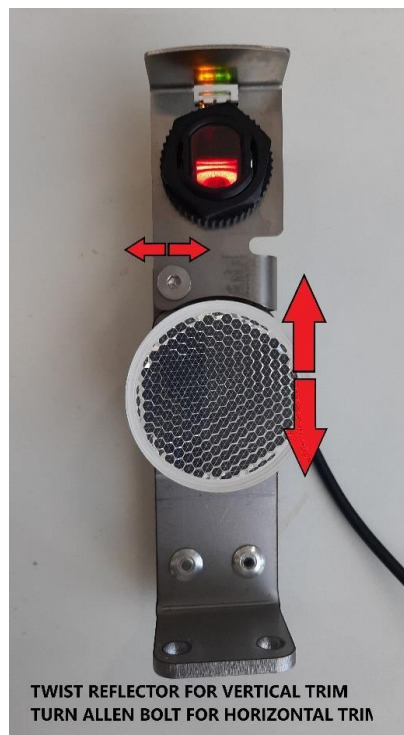

**Step A.** Right Hand Side: trim the horizontal and vertical angle of the PEC by turning reflector clockwise to raise beam and anticlockwise to lower beam. Use the 2.5MM Allen head screw as shown to adjust the beam horizontally. For best results ensure lower PCB cover is installed on the opposite gate while setting PEC sensor as beam may not align once cover is installed

**Step B.** Break the beam and test gate operation: Rear gate should now close once PEC sensor receives is signal back from opposite reflector and gate should open once signal is broken. **Important:** when PEC is set (trimmed) correctly, both the yellow & green lights will be steadily on, at the same time – see image below.



10. Gate Arms should always be facing nose up/nose down as shown below:



## 11. LED Cable Set Up

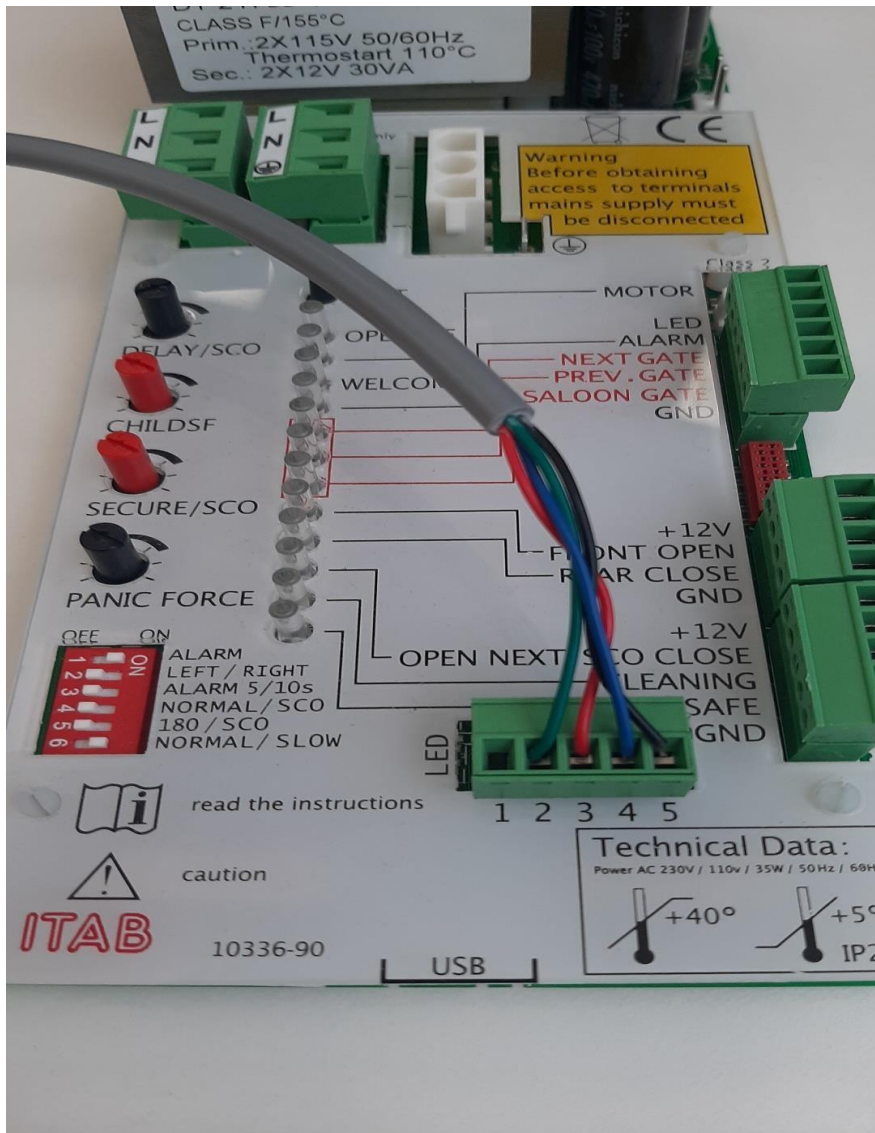

1. NIL
2. Green
3. Red
4. Blue
5. Black

Gate arms should illuminate Blue when at rest and Red when in alarm. No other colours should be present.

## 12. Clean down gate equipment, including post and rails.

## 13. Remote control installation and testing.

Please note that this is our Generation 3 Receiver/Remote Control set with 4-channels.

### 1. Mount the Receiver



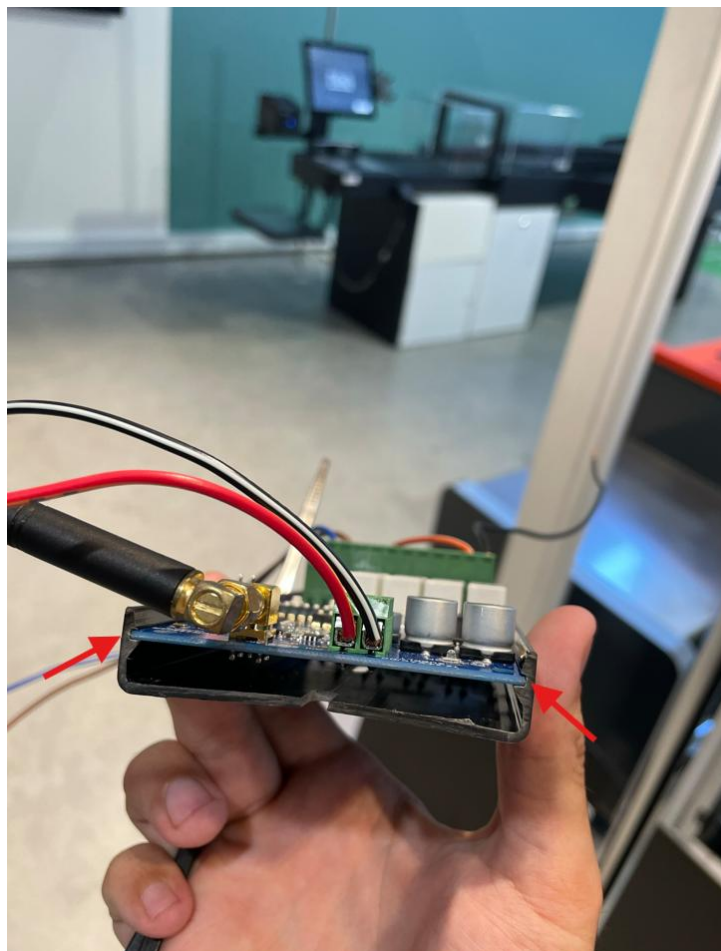

1. Fit the receiver into the plastic bracket. Fit it into the trace.



2. Fit the receiver in the right-hand side gate. Place it according to the picture and secure with one cable tie.

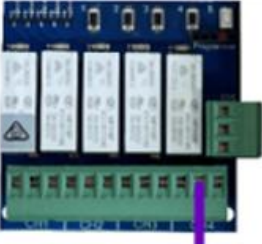

## 2. Wire the Receiver to AlphaGate Control Board

Receiver	Sigma Gate Control Board
Supply + 	12V
Supply - 	Ground
Ch4 NO 	Cleaning
Ch4 C 	Ground

\*Please note that the terminals are misaligned to the labels on the blue face, it is important to count the terminals as displayed above.

### Connecting Power

1. Open the AlphaGate panel.
2. Connect **Supply +** to **12v** on the Alpha control board.
3. Connect **Supply -** to **Ground** on the Alpha control board.

### Relay 4 (Latched/Cleaning Mode)

1. Connect **Ch4 NO** to **Cleaning** on the Alpha control board.
2. Connect **Ch4 C** to **Ground** on the Alpha control board.

## 3. Set the DIP Switches & Pair Remotes

1. Change Mode Selection on the 6 DIP switches (outlined in red below) to OFF OFF OFF ON OFF OFF or Down Down Down Up Down Down.

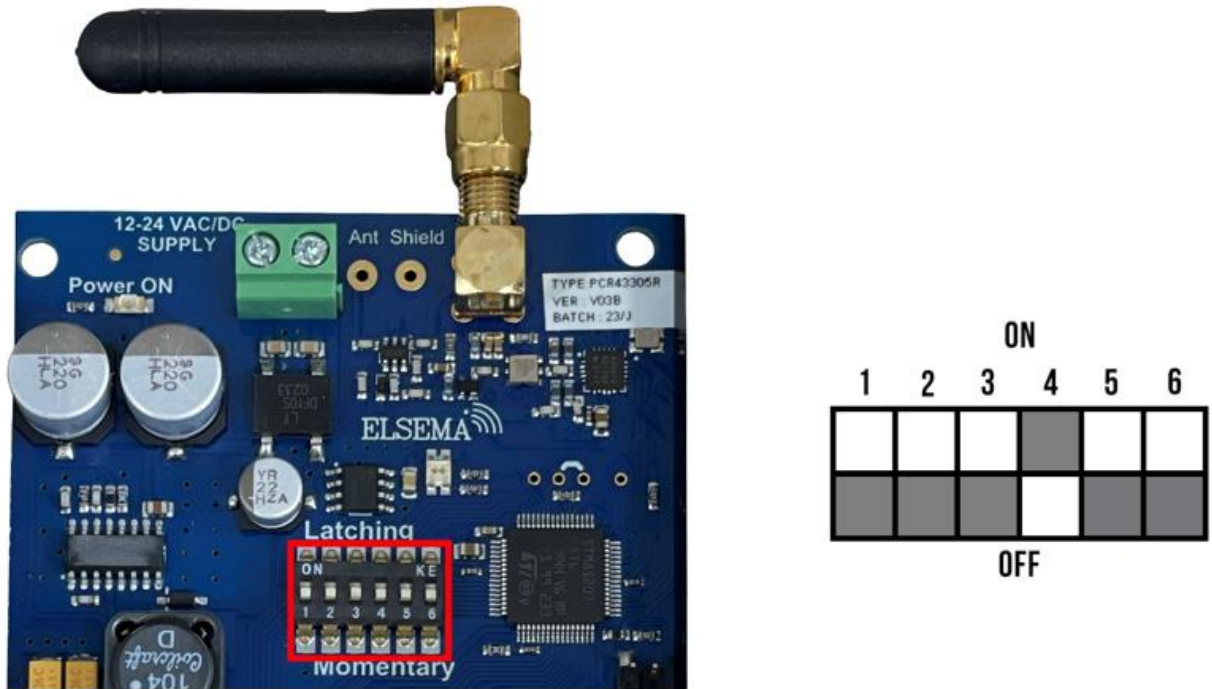

2. On all receivers set switches 1-10 (outlined in green below) to match the store number using the examples in the table below. As an example if the store has a number 8 in the store number set DIP switch 8 to the ON/Up position and ignore any zeros in the store number. If the store has the same number more than once like 8888 only switch 8 must be set to ON/Up and rest will be down/off.

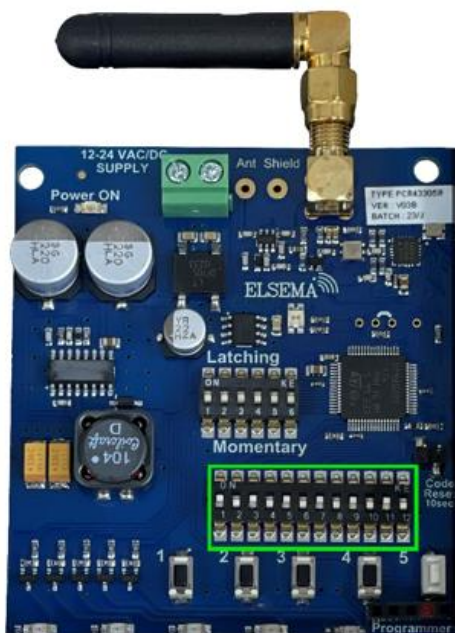

Store #	DIP Switches 1-10									
0043	ON									
0333	ON									
3571	ON									
3344	ON									
1364	ON									

3. The table below explains Dip switch 11 and 12. The first receiver should always have Off/Off.

If you the store has two receivers. The first should have Off/Off and the second should have On/Off. Follow the table for all the different set ups.

	Receivers Dip Switch 11	Receiver Dip Switch 12
<b>Receiver 1</b>	Off	Off
<b>Receiver 2</b>	On	Off
<b>Receiver 3</b>	Off	On
<b>Receiver 4</b>	On	On

4. Set DIP switches 1-10 in the remote exactly the same as the receiver. Dip switch 11 and 12 should always be Off/Off.

5. Lastly insert the battery in the remote and test.



14. **Sign Off Document** – Do a final test with site Foreman, asking Foreman to sign your paperwork confirming he is happy with full operation of the gates including “time” settings.

## Sign Off Document

I can confirm that the gate has been successfully installed and is in full working order.

I have received the key for isolating the gate when required	
I have tested the distance of sensor triggering (pick up patron advancing) we recommend 1.2 meters to 1.5 meters	
I am satisfied with the timing of how long the gate stays open before automatically driving back to the closed position – we recommend 4 seconds for Coles operations.	
I have tested the alarm sounder cancelation (we recommend 5 seconds) before returning to normal operation	
I am satisfied with the gate arm selection speed – slow mode	
All 4 remote controls operate as stated within manual	

Date:

Name:

Signed: