

++

Radford.

Installation Manual

Prepared by Dominic Casey for
Woolworths

(01/11/2021)

Revision 2.1

Woolworths Itab Alphagate
Kit 2 manual

The aim of kit 2 and associated manual is to convert a phase 1 (single gate) welcome gate assembly to a new type kit 8 (stockloss) assembly with new lead in rails and bumper rail kit.

Before commencing work onsite please see drawings and images below. Please take note that the existing Phase 1 gate assembly and associated rails will need to be integrated into the components of kit 2 to complete the installation.

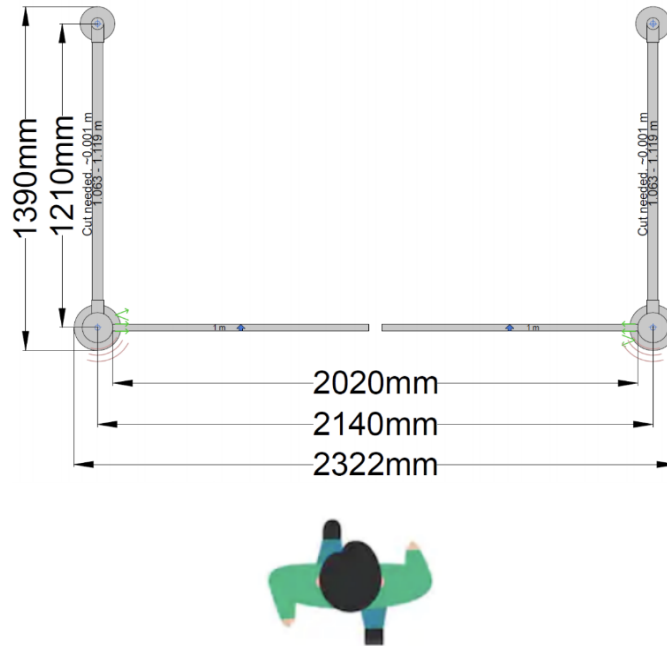

Existing phase 1

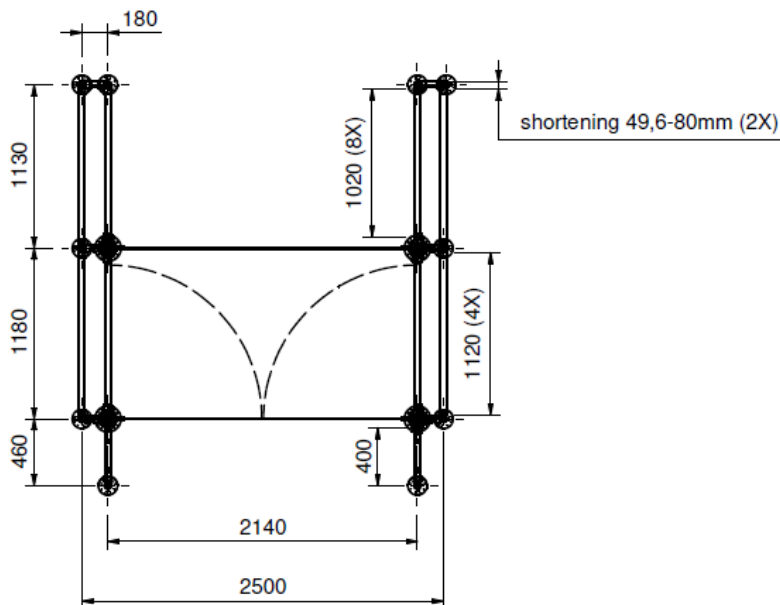

Finished kit 8 after applying kit 2 components

The existing welcome gate assembly must be carefully removed as parts from this gate are used in new kit8.

- Power supply isolated.
- Remove glass gate arms.
- Remove lower PCB cover on gate bollards. (please take special care not to damage cables)
- Ensure power and data cables are disconnected from gate bollard PCB.
- Loosen all grub screws securing existing rails in place.
- Remove upright end posts.
- Remove cross rails. (rails may need to be cut to size for kit8)
- Remove gate bollards.

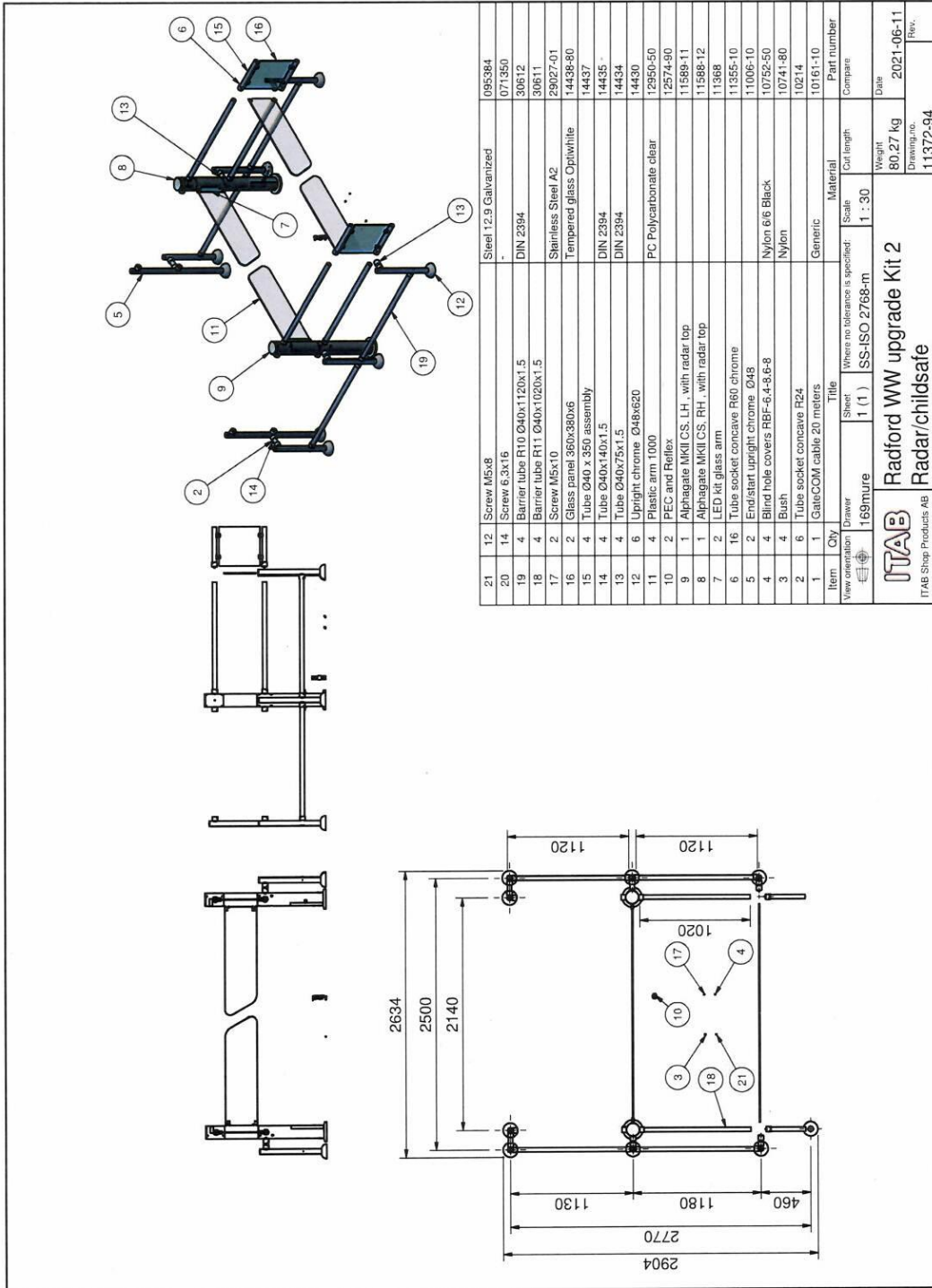

PROPRIETARY AND CONFIDENTIAL. The information contained in this drawing is the sole property of ITAB Shop Products AB with corporate number 556132-046, a company within ITAB Group. Any reproduction or use in part or as a whole without the written permission of ITAB Shop Products AB is prohibited. The drawing shall be returned to ITAB Shop Products AB immediately upon request.

ALL MATERIALS MUST BE ROHS COMPLIANT

Woolworths Kit 8 (Stockloss) Itab autogate installation and commissioning Manual

(Created by Dominic Casey - Radford Retail Solutions P/L, dated: 14/07/2021)

shortening 49.6-80mm (2X)

Item	Qty	Title	Material	Part number
18	1	GaeCOM cable 20 meters	Generic	10161-10
17	10	Tube socket concave R24		10214
16	4	Erectislat upright chrome Ø48		11006-10
15	20	Tube socket concave R60 chrome		11355-10
14	4	LED kit glass arm		11368
13	1	Alphagate MKI Childs. STD LH		11516-11
12	1	Alphagate MKI Childs. STD RH		11517-12
11	1	Alphagate MKI Childs/Radar LH		11519-11
10	1	Alphagate MKI Childs/Radar RH		11520-12
9	4	Plastic arm 1000	PC Polycarbonate clear	12950-50
8	6	Upright chrome Ø48x620		14450
7	4	Tube Ø40x75x1.5	DIN 2394	14454
6	2	Tube Ø40x140x1.5	DIN 2394	14435
5	4	Tube Ø40 x 350 assembly		14437
4	2	Glass panel 360x306	Tempered glass Ophtwhite	14438-80
3	8	Barrier tube R11 Ø40x1020x1.5		30611
2	4	Barrier tube R10 Ø40x1120x1.5		30612
1	10	Screw 6.3x16		071560

View orientation	Sheet	Where no tolerance is specified:	Scale	Cut length	Complete
180mm	1 (1)	SS-ISO 2768-m	1 : 30		

ITAB Radford WW standalone Kit 8 Radar/childsafe

ITAB Shop Products AB

Weight 98.43 kg
Drawing no. 2021-05-31
Date 2021-05-31
Part number 11372-91
Rev

PROPRIETARY AND CONFIDENTIAL: The information contained in this drawing is the sole property of ITAB Shop Products AB with corporate number 561132-066, a company within ITAB Group. Any reproduction or use in part or as a whole without the written permission of ITAB Shop Products AB is prohibited. The drawing shall be returned to ITAB Shop Products AB immediately upon request.

ALL MATERIALS MUST BE ROHS COMPLIANT

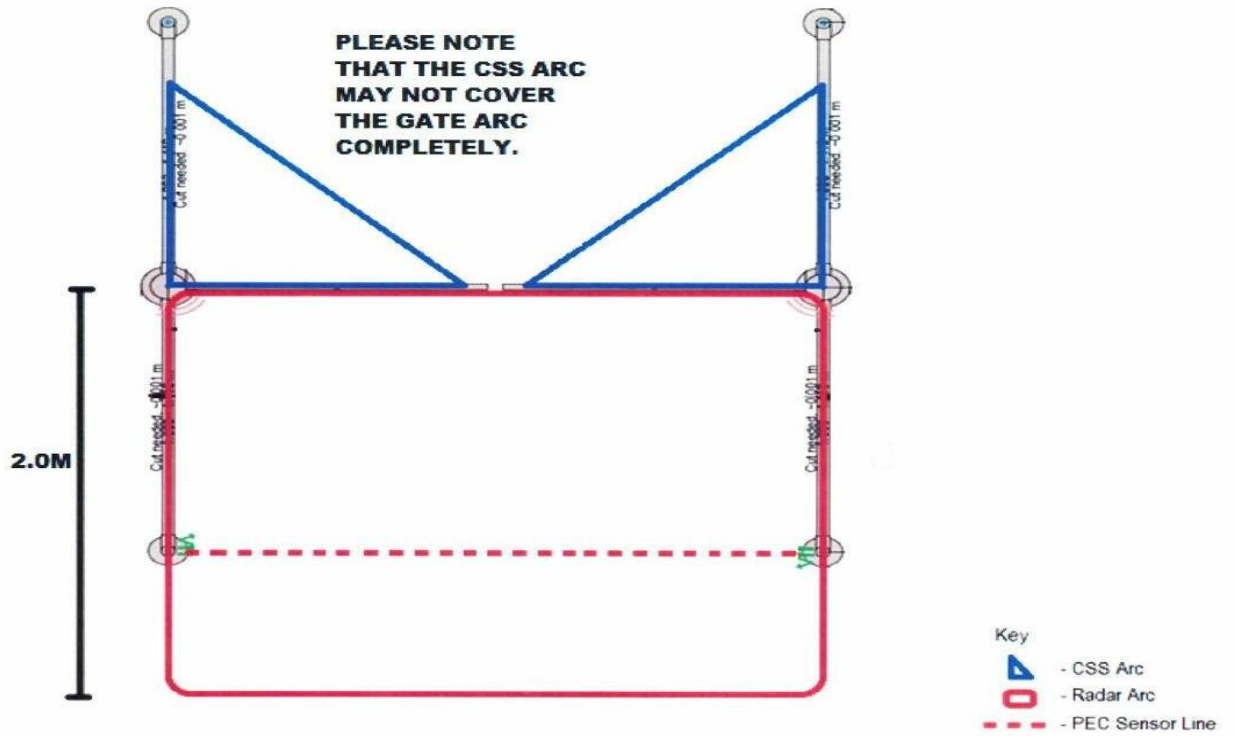

STORE ENTRY

Woolworths kit 8 Itab autogate manual contents:

Follow the installation steps as per items 1 to 20 listed below:

- Item 1.** Unpack materials from carton and ensure all components are fully intact.
- Item 2.** Layout bollard and posts as per above drawing and confirm measurements.
- Item 3.** Drill floors fixing and fit gate bollards only, firmly into the ground to begin with.
- Item 4.** Terminate synchronisation cable connections between gate bollards.
- Item 5.** Fit polycarbonate arms to Woolworths Itab Alphagates.
- Item 6** Fit rear lead-out post and rails inc. low-level outer protector rail system.
- Item 7.** Power alignment of gate arms.
- Item 8.** CSS device may have already been fitted to the gate bollards, if not fit same.
- Item 9.** Fit new type radar sensor cover-strip (if supplied) before CSS commissioning
- Item 10.** Install lead in upright post and rails.
- Item 11.** Check PEC assembly
- Item 12.** Set up dip switches on the controller board.
- Item 13.** Set up and commission master & slave function in gate bollards saloon
- Item 14.** Set up & commission PCB controller timing.
- Item 15.** Set up & commission sensors.
- Item 16.** Check Woolworths's wiring configuration for gate arm LED colours.
- Item 17.** Check gate arm assembly component breakdown.
- Item 18.** Check approach radar triggering area box complies.
- Item 19.** Check Woolworths Itab entry gate arms orientation image.
- Item 20.** Check Wiring link for audible alarm triggers if gate arm arc area is penetrated.

- Item 20.** Complete separate sign-off checklist.
- Item 21.** Complete separate sign off sheet.
- Item 22.** Check sensor adjustment video

1. Unpack materials from carton and ensure all components are accounted for and fully intact.

See Bill of Materials on page 1 complete with drawing of gate layout.

2. Layout the bollard and posts as per above drawing and confirm measurements with site foreman, before drilling.

Once measurements are confirmed, mark out drilling points and floor chase line for main bollards only, before moving equipment away for drilling and floor chasing.

Important considerations:

- a. Drill holes into the ground and fit both bollards **before** drilling the fixing holes for the upright lead in sensor posts or the lead out rail upright posts, then complete floor chasing for power and synchronisation cabling – use 90-degree conduit elbows to allow cables to penetrate through the **centre** of large centre cut-out in base plate.
- b. 10 amp power is required for each gate bollard (centre to centre of bollard usually via underground) see below fixing plate dimensions. Power terminations at **bottom** of gate bollard only – gate may be severely **damaged** by running power cables through the gate bollard!
- c. A synchronization cable is required between both gate bollards in each individual front & rear gate couples (centre to centre of the bollard base and usually via underground floor chase).

Note there is also a separate stand-alone data cable (twin wires) that is **linked** from the **front** gate couple to the **rear** couple – this interconnection brings the signal from the front bottom- mounted PEC to the to open the rear gate couple as the sole source of triggering the rear gate couple.

Plan synchronisation cables and chase floor: Front and Rear gate couples operate completely independently, however the Rear gate couple is triggered by a photocell eyes (PEC) which is mounted into the bottom of the Front gate couple gate bollards.

Before chasing the ground note there are three 3 totally independent twin-core cables to be run:

1. Gate A to gate B (Saloon to Saloon & GND to GND)
2. Gate C to gate D (Saloon to Saloon & GND to GND)
3. Gate A to gate C: (from “next gate” on gate A to “prev. gate” on gate C & GND to GND)

Care should be taken not to damage cables when fixing bollards to the ground – sync. cable may be installed into the same floor-chase, separated by protective conduit.

Alphagate bollard base plate dimensions:

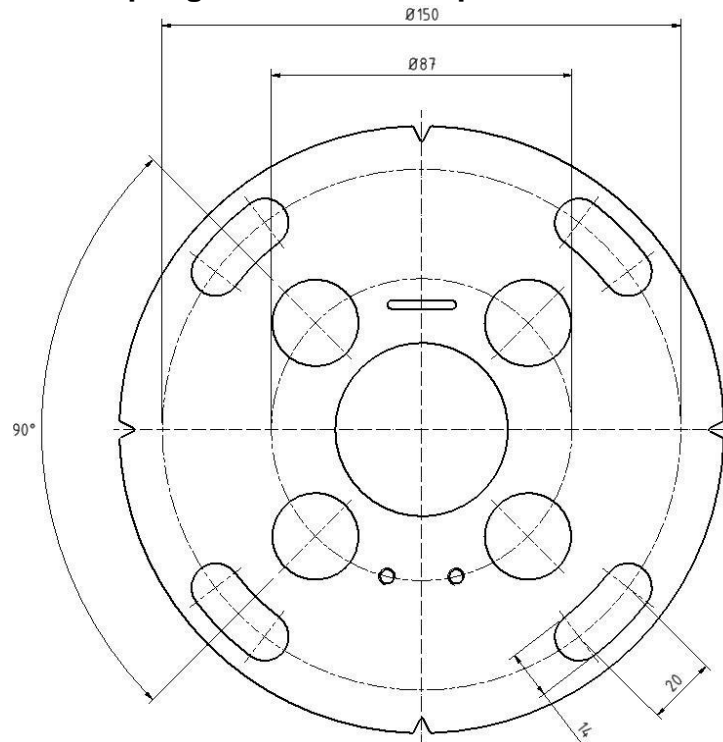

Adequate fixings penetrating at least 75mm **into** the floor, with flat washers and spring washers are recommended (builder or Architect to nominate fixings). If floor concrete is inadequate for standard fixings Chemset-bolt solution or similar should now be used to repair any loose bolts.

d. Understanding the synchronisation cable functions:

- **Front saloon-gate couple (A & B)** = connect to “saloon gate” & “ground” terminals at both ends when triggered by their inbuilt (top mounted) radar sensors, these gates will now operate as one gate couple.
- **Second saloon-gate couple (C & D)** = connect to “saloon gate” & “ground” terminals at both ends – when triggered by (front- gate-mounted) photocell eyes, these gates will now operate as one gate couple.
- **Interconnecting data cable triggering of second saloon-gate couple:**
 - Gate A = connect to “*next gate*” & “*ground*”
 - Gate C = connect to “*previous gate*” & “*ground*”

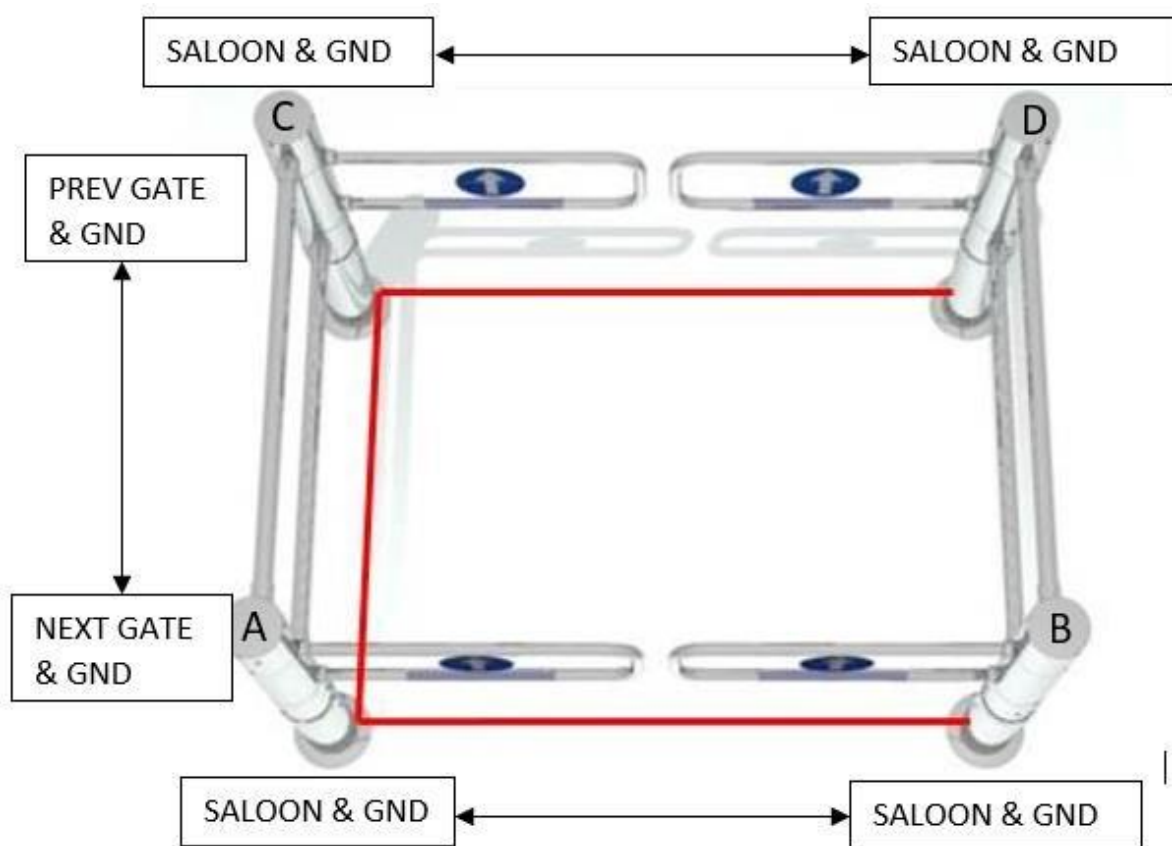

3. Drill floors fixing and fit gate bollards-only firmly into the ground, to begin with.

Chase floor for power and data cables and drill holes into the ground, then fit both bollards (front gate couple first then rear gate couple), **before drilling the fixing holes** for the upright lead-in or lead-out posts. Use 90 deg. conduit elbows to allow cables to penetrate the **centre** of cut-out in base plate.

After studying item 2 above, in detail, bolt gate bollards firmly into place ensuring they are installed in an as aligned position, as practicable.

4. Terminate sync. cable connections between each gate couple:

Saloon & GND to be connected via underground to facing gate controllers for each separate front and rear gate couples -see below.

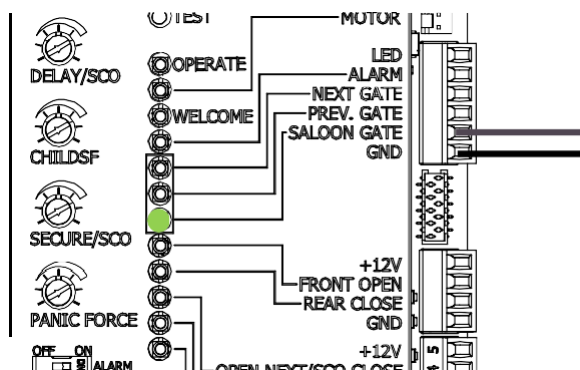

5. Fit polycarbonate arms to Woolworths Itab Alphagates

Before power is connected to gates you must fully understand the following information below before attempting to fit the gate arms, otherwise the equipment may be severely damaged:



It is very important to make sure that ALL components are fitted to the gate arm bracket correctly before placing the polycarbonate arm into the metal bracketry, otherwise breakage is likely to occur either on the spot or later during normal operations.



Ensure the rubber gaskets (there are two, one each side of the gate arm panel) are fitted correctly – no arm materials should come into direct contact with metal components at any time.



Ensure **BOTH** plastic spacers are fully intact and firmly in place on metal mounting shaft – the gate arm should not come into direct contact with metal components at any time.



Ensure no cables associated with LED lighting strip are **not** damaged before fitting (and during fitting) of gate arm panels.



Arms should be placed with equal spacing (there should always be a minimum of 100mm for safety reasons) between gate arm panels ends, which are fitted with a sloping offset design – see item 17 below.



All fixing screws should have **thread lock** applied to their ends before final tightening - ensuring they are firmly countersunk flush into outside-metal fixing panel.



Remove ALL gate arm protective coverings including the section that is inserted into fixing bracket as this may reduce the LED visibility of the gate arm lighting.



Carefully fit new arms ensuring all fixings, spacers and rubber gaskets are correctly and firmly fitted into their place before inserting fixing screws.



Do not tighten gate bollard cross rail cups or upright post cups set screws until gate arm panels are fully installed into fixing brackets and fully aligned into the 90-degree position below the cross rails – this allows for a more flexible gate arm alignment when in the **fully opened** position.



When fitting gate arms into their brackets, ensure the (2 per gate bollard) plastic buckets spacers are in place (**making sure there are no direct metal bracketry to gate arm contact**) and are fully inserted into the (2 gaskets per gate bollard) rubber gaskets which sandwiches the arm and in turn separates the gate arm panels from the metal brackets.

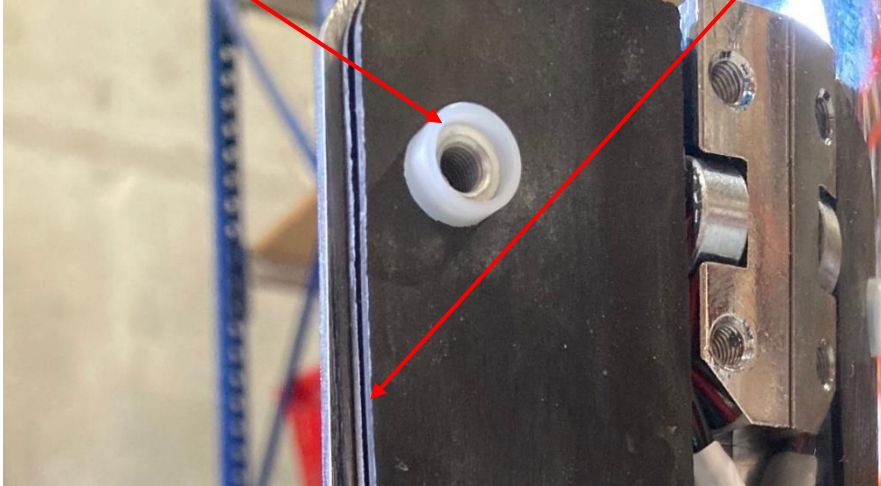

Gently tighten gate arm bracket screws until the plastic spacer flattens up tight to the polycarbonate arm panel. Make sure check that the rubber gasket and plastic spacers are not overlapping each other, and all components are aligned correctly before firmly tightening all gate arm fixings in place.



Please note operating the gates with loose gate arm-fixings, missing screws or missing rubber seals will damage the arms over a very-short period of time.

(Important: replace or report any missing screws or caps when completing checklist)

6. Fit lead-in and lead-out post and rails:

- a. Fit **cross rails** between front and rear gate bollards – adjust the bollards base plates as required to achieve a good alignment between bollards, cross rails and fully open arms.
(Arms should sit squarely under cross rails when fully opened)
- b. Fit **lead-out post and rails** - adjust end posts & bollards base plates as required to achieve a good alignment between bollards, cross rails and fully open arm. (Arms should sit squarely under cross rails when fully opened)
- c. Fit **lead-in post and rails** - adjust end posts & bollards base plates as required to achieve a good alignment between bollards, cross rails.

7. Power alignment of gate arms:

Powering up the gate bollards at this point will allow you to achieve arm alignment more accurately. Important make sure **NO** sensors are fitted to the gate bollards when you do this.

With the gate bollards are powered up with **no input sensors connected** the gates should power into the normally closed position – before taken the next steps ensure, complete a, b & c below:

- a. go to left-hand gate bollard PCB and ensure the # 2 gate dip switch is flicked to left.
- b. go to right-hand gate bollard PCB and ensure the # 2 gate dip switch is flicked to right.
- c. adjust the gate arms to a centralised position - see gate arm adjustment instructions below:

Note: gate bollards will be severely damaged if you do not strictly understand and follow the gate arm adjustment process, which starts by making sure you understand “why” you need to remove all sensor inputs before you attempt to adjust fully open position of the gate bollard arm.

To assist with the gate arm alignment commission newly installed gate arms as per arm alignment/adjustment process listed directly below:

- a. Ensure all radar, and CSS sensors are disconnected **completely for this task**: ensure there are no sensors in circuit while the Allen key adjuster tool is inserted in the coulisse (*electronic encoder circuit/position sensor*) otherwise, if the sensor is in circuit, they may trigger the motor to activate with the tool still in place and this tool will move with the shaft and jam against the metal casing (see image of gate cut out for Allen key adjustments below) – **ignoring this may severely damage the coulisse beyond repair and void warranty completely.**
- b. If the gate arm needs to be adjusted for alignment, providing you are sure there are no sensors in circuit, loosen the locking screw that holds the coulisse (electronic encoder circuit/position sensor as shown in the image below) with 3mm Allen key and move the coulisse a little bit to the left or to the right depending on how the gate arm needs to be adjusted.

To do this adjustment power needs to be switched on (with the key) to the gate bollards. Move adjustment tool carefully as **small** adjust the arm position several centimetres.

When the gate arm is satisfactory adjusted, fasten the locking screw again – do not over tighten the locking screw.

Move Allen Key to the right
➤ gate arm moves to the left.

Move Allen Key to the left
➤ gate arm moves to the right.



At this point both gates bollard arms should be aligned with each other satisfactorily, when powered up.

Ensure the synchronisation cable terminated between saloon & GND on both gates the insert a temporary wire link on one gate couple bollard, between Cleaning & GND.

With the temporary link wire in place, and the gate powered on at the key switch, gates should be open to the fully opened 90-degree position, thus allowing you to check, adjust & align lead-out posts and rails with the fully opened arms as required. Ensuring the gate arms sit directly under the centre of the cross-rail position when fully rested in the open position.

Adjustments can be made from four positions:

1. Coulisse adjustment
2. Gate bollard base plate adjustment
3. End-post base plate adjustment
4. Cross rail cup adjustment (gently tapping with rubber hammer)

Important: remember to remove temporary wire link when finished above task.

8. Check the CSS device have already been fitted to the gate bollards.

In some circumstances CSS kits may be supplied separately and will require onsite fitting – see kit contents and installation position images below.

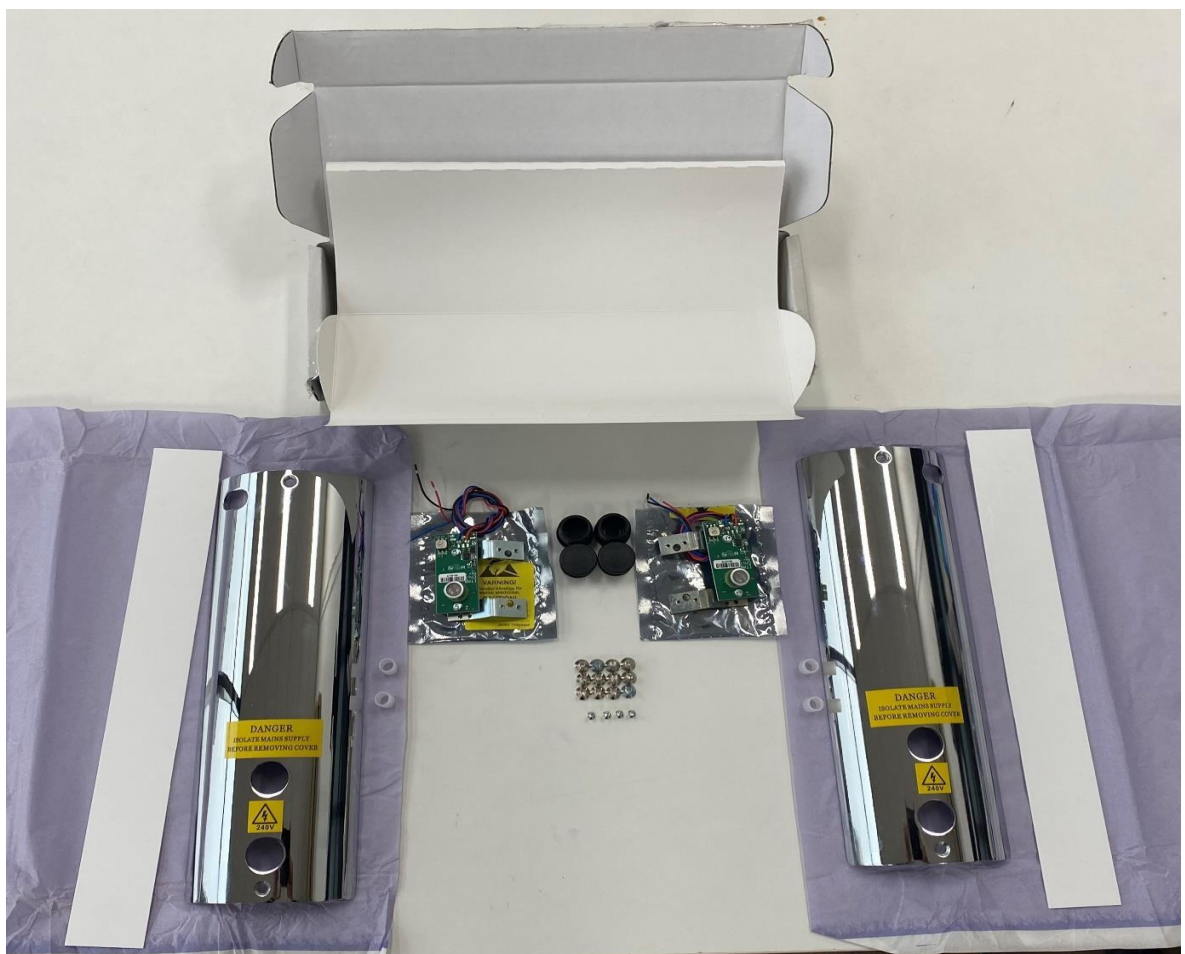



Note there are left and right-hand fixing brackets for individual gate bollards.

Child safe sensors are ultrasonic sensors that are used as a safety device to help protect patrons from encountering the moving gate arm. The ultrasonic sensor is a presence sensor designed to detect the presence of a person in the area behind the gate where the gate arm rotates.

It is very important that there are no obstacles within the detection area, for example it is important that uprights posts are installed at the correct length away from the gate bollards, so as the sensor **does not** detect the actual upright posts – make sure CSS are fully tested as per checklist upon installation completion.

CSS wiring terminations to autogate controller should be checked for completeness:

Red = + 12 V

Black = GND

Blue = Child safe (signal)

Fit a permanent wire link between “open next and CSS on each gate bollard for audible alarm.

*(CSS alarm only sounds if the gates are fully closed **before** a patron enters the rear gate arm arc)*

Final sensors testing can only be assured when covers are fitted back onto bollard and the radars sensors have been fully commissioned (see caution notice below)

Caution:

- Please make sure there are no-loose fixings on the child safe bracketry as this will produce false triggering.
- The store manager needs to be advised **not** to place baskets, shopping carts or any other objects close to the child safe sensor detection area behind the gate arm otherwise gates will stay in the open position.
- Please make sure there are no wires or objects blocking the front of the child safe sensors as this will produce false triggering.
- Please be careful as the CSS device as this is sensitive and can be easily damaged while installing, particularly when **removing** and **refitting** the gate bollard front cover plate.

Important: the front cover metal case should **not-touch** the metal casing of the sensor assembly (see below image) – if adjustment needed, gently bend the fixing bracket with pliers as required.



9. Fit new type radar sensor cover-strip (if supplied) before CSS commissioning commencem



(Radar cover slides in & out without fixings cover to join to the side away from gate bollard cut out)

10. Install lead in upright post and rails:

Align upright posts at 90 degrees to gate arms mark floor fixings, remove posts and drill floor fixings holes. Fit posts and rails as straight as possible with the rest of the layout ensuring the PEC and reflector posts are fully aligned with each other. When satisfied post & rails are squarely aligned, fit glass infill panels, ensuring the plastic spacers (separating glass from metal) for fitted firmly in place.

11. Check the PEC assembly has been pre-fitted on front gate bollards:

If provided separately, fit same by fixing to gate bollard base plate and terminate as below:

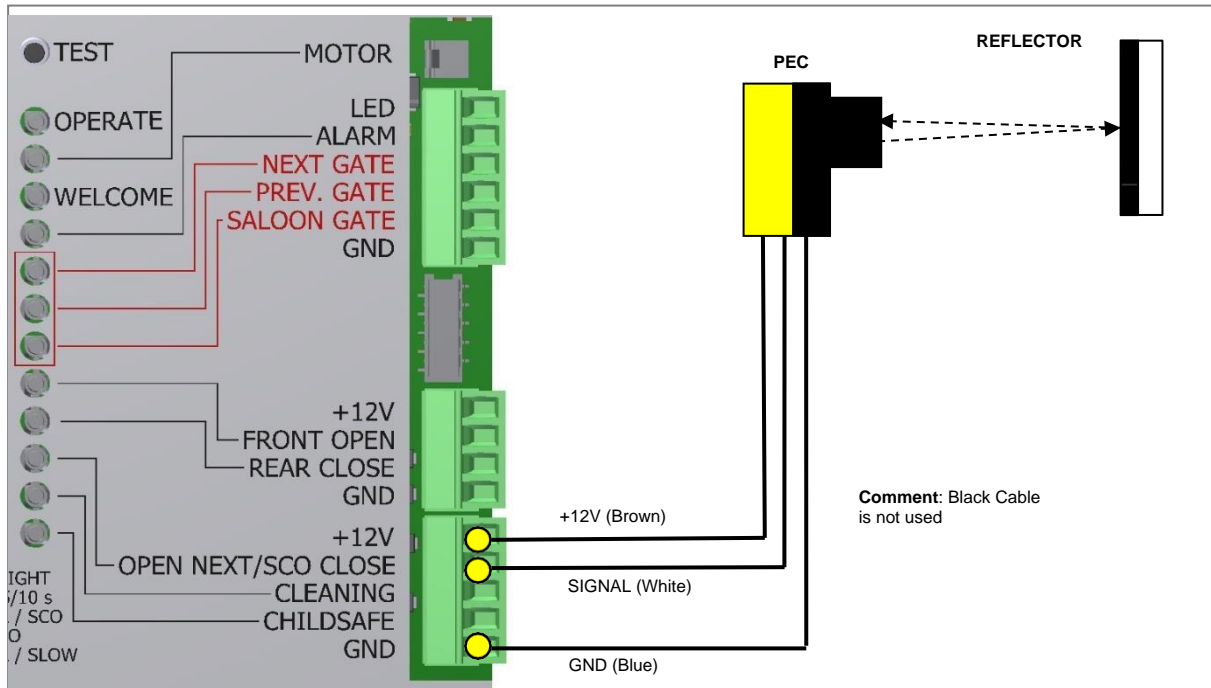

This PEC triggers the rear gate couple and is mounted into the front gate bollards.

In this system the PEC triggers the rear gate couple open when an object breaks the infrared beam (passing shopping trolley wheel or a patron's foot) and closes automatically after a set period, once the object has been cleared from the beam.

This period can be varied by adjusting the right-hand gate bollard (Delay/SCO) potentiometer, located on gate bollard main PCB. When setting up the PEC alignment with reflector, the open time delay should be set to "min position" (anti-clockwise) on the time delay potentiometer (Delay/SCO) on the control board located in the bollard. Final adjustment and timings will be set at commissioning stage.

- **Set up front mounted PEC trigger for rear gates:** terminate date cable front and rear gates couples (gates A & C)
- Set up the right-hand PEC sensor only and unplug the left-hand sensor, if installed - use the left-hand sensor assembly as a reflector only.

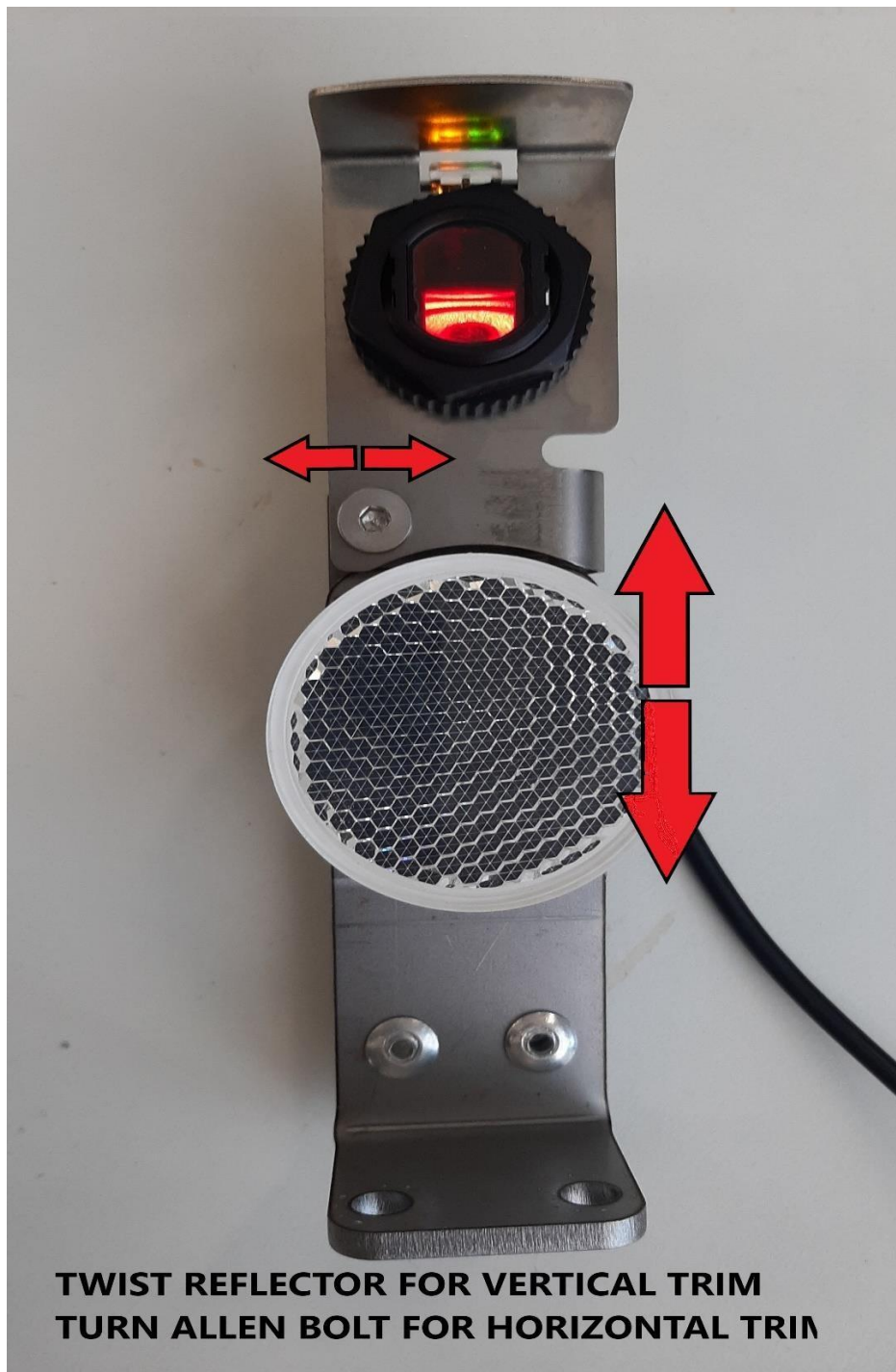

Break the beam and test gate operation: **important:** when PEC is set (trimmed) correctly, **both** the yellow & green lights will be **steadily** on at the same time – see image above.

12. Set up dip switches on the controller board:

Note: upon store entry: gate on left = left-hand & gate your right = right-hand.

Dip switch block settings on both **left & right-hand**

gate bollards: 1 = right position

2 = left **or** right position (left hand gate = select left) (right hand gate = select right) 3 = Right position

4 = left

position 5 =

left position

6 = left

position

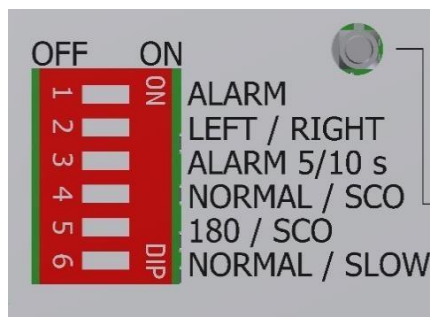

13. Set up & commission master & slave function in gate bollards to operate as a saloon couple – see potentiometers on main controller:

Left-hand gate (Slave)

- Set DELAY/SCO and SECURE/SCO potentiometers to maximum: (Set fully to the right-hand position).
- Set CHILDF potentiometer to minimum: (Set fully to left hand position)

Right hand gate (Master)

- Set DELAY/SCO potentiometer to full left and then approx. 25% of its full range to the right position, as a starter point, before final timing adjustments are made later.
- Set CHILDF and Secure/SCO potentiometer minimum: (Set fully to left hand position)

Check that the gate synchronization cable is correctly connected between both gates (saloon to saloon and GND to GND) this then ensures the gate couple will be controlled as one-unit and **all** adjustments made to the **right-hand** controller delay timer will control both right and left-hand gates alike.

(Note: right-hand gate is set up as the master & left-hand gate is set as the slave)

Double-check final settings for PCB potentiometers as per below, before commissioning gates:



DELAY/SCO

(Left hand gate)

← Set fully to right position (to set up master & slave function)



CHILDSF

← Set fully to left position (to ensure CSS min. reset time)



SECURE/SCO

← Set fully to right position (to set up master & slave function)



PANIC FORCE

← Set to mid position (to ensure gate arm break out force is moderate)

(Right hand gate)



DELAY/SCO

← Set fully to left, then adjust slightly to the right "if required" for a 2 second delay.



CHILDSF

← Set fully to left position (to ensure CSS min. reset time)



SECURE/SCO

← Set fully to left position (to set up master & slave function)



PANIC FORCE

← Set to mid position (to ensure gate arm break out force is moderate)

14. Set up & commission controller timing on PCB:

- Remove the lid on top of **each** gate bollard and **disconnect** the radar electrical connectors on **both** gate bollards to (**temporarily**) render the radars out of circuit. Then power up gates and press the test button on the master gate (right hand gate) and both gates should now operate as a saloon-gate couple (**both gates should open and close at the same time – ensure PEC sensors are not blocked during this test**).

After the test button depressed as per above, the gate couple (both left and right-hand gates) should open **into** the store, stopping in the 90-degree (fully open) position and remain open for a pre-set time before driving back to the fully closed position.

- Real-life time delay can be tested later by triggering radars during radar set up step during commissioning. (Time delay potentiometer will adjust this timing - remembering left is least).
- The time-lapse (time gates remain fully open) for both gate bollards can now be adjusted by the master (right-hand) gate DELAY/SCO potentiometer whereby both gates should operate and close at the same time - the recommended time delay (time-lapse) between the gates **after** they have **reached** the fully opened position and the time the gates **start** to drive back to the closed position should be approx. two (2) seconds. This time delay setting can only be successfully adjusted after the sensors have been refitted.
- Adjust panic force potentiometer (break out function) by winding full left (off) position and then wind to the full right before setting to the (approx. the 75% position) final position.

This above final setting will produce a **moderate** breakout force required to push out the gate in the event of an emergency.

Caution: if breakout force is not adjusted sufficiently, the gate will regularly false alarm!

Notes:

- A.** In normal operations the gate arm drives to the open position, at the last 10 to 15 degrees the gate arm slows down before coming to a full stop at the 90- degree position - this is a normal design feature design to reduce the impact when the gate arm mechanism meets its mechanical stops in the fully open position.
- B.** Breakout adjustments may be required (force increased) to help reduce excessive arm movements when the gate arm reaches the fully stopped position.

15. Set up & commission sensors:

Commissioning and adjustments **cannot** be completed successfully without having full access to the store with the entry roller shutter fully in the **open** position, as in a real-time situation.

****See video link below before commissioning of sensor** – QR code also on page 27. <https://youtu.be/lmyngCrtN0s>

Recommended sensor adjustments sequence: adjust sensors **A**, then **B**, then **C** as below.

A. Radar commissioning should be adjustments to detect approaching patron from 2m away:

(Disconnect the CSS temporarily during this test)

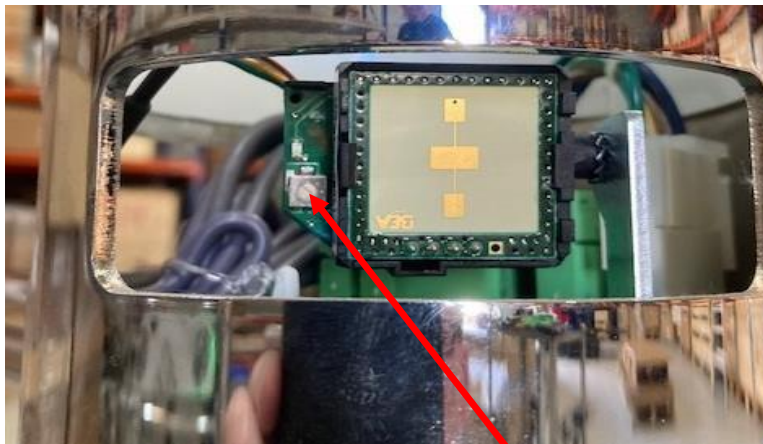

There are 3 radar adjustments as follows:

1. = left or right adjustments as per Allen key bollard fixing screw
2. = up and down as per side radar bracket fixing screw
3. = pick up distance as per potentiometer adjustment on radar device

Both gates in the saloon-gate couple are fitted with radar controllers (either gate bollard radar will trigger the gate couple) to trigger the gate-couple as one unit.

- Connect the electrical connectors back onto the radar units and adjust the mechanical radar bracket on **each** gate into position - the radars should be pointing in the general forward position and slightly into the middle of the gate arms centre. Radar should also be pointing **slightly** down towards the floor to pick up shopping trolley wheels as a trolley approach and to avoid ghost signals being picked up from above.
- Remove the inner white plastic radar cut-out cover (slides out by hand) and adjust the radar approach sensor triggering distance potentiometer on the top of radar sensor to the full left-hand (off) position, then adjust in small increments to the right until the gate radar is picking up a forward **moving** person or object at 2m, measured from the gate arm.

- Disconnect **each** radar electrical connector (one at a time) and test the remaining in-circuit radar sensor distance picks up a trigger signal from 2m from the gate bollard and opens both gates fully – each individual gate bollards radar sensor should pick up approaching patrons across the full width of the arm and include a little overlap to the other arm position.
- Ensure electrical connectors are re-connected firmly into both radar units and ensure cables are secured with a cable-tie to prevent false triggering. Please also note that **loose** radar brackets (or gate bollards fixings) will cause **false** triggering.

B. CSS Commissioning: ensure CSS unit has been re-terminated (see item 8)

Ideally the CSS detection arc should be the same length as the gate arm, however this is not always possible (as ultrasonic sensor range are sensitive and device adjustment varies slightly from site to site and from device to device).

It is recommended to set as large a CSS detection arc as possible, the larger the protection arc the safer the entrance will be.

To adjust the range for the CSS detection arc, turn the potentiometer clockwise to increase the detection area and anti-clockwise to reduce the detection area – see chart below.

The Woolworths arm size in this instance is 1000mm long and as per the below chart the number 5 should be selected first as this matches the 1000mm range to begin with.

Please note, due to site and device differences the number 5 is the **starting point** only for commissioning purposes – further adjustments up or down are usually required.

In most cases you will not achieve full ultrasonic coverage behind the entire gate arms arc and a compromise will need to be established.

Each gate arm operates independently - consider the following example: if say the left gate arm arc has more CSS coverage than its own gate arm length (too much coverage) it may detect beyond the length of its gate arm and detect the presence of the opposite gate arm, this in turn will wrongly stop the gate from operating. ***(The compromise will be to reduce the range back to usually less than the gate arm length, rendering a small area between both gate arm ends with no detection at all)***

During normal operations, a patron would approach the gates at average walking speed whereby the radar would pick them up at a triggering distance of **2m** away – as itemised in checklist test.

In this situation (triggering the radar at **2m**) the gates would usually be fully open **before** an approaching patron passes the gate bollards (remember the radar produces a continuous triggering signal to open the

bollard so long as the patron keeps moving towards the gate bollard) therefore as the patron steps into the **rear** gate arm arc its presence will trigger the CSS ultrasonic sensor to keep the gate arm open (regardless of how slow a patron might be) until the entering patron is almost into the store.

PCB Range Selection Chart.



Setting	Range (cm)
0	75
1	80
2	85
3	90
4	95
5	100
6	105
7	110
8	115
9	120
A	125
B	130
C	135
D	140
E	145
F	150

Select setting **#5** initially to match the 1000mm arms & adjust up or down as required. (See checklist for testing instructions and adjust to comply if required)

Note, there may be an issue if a patron walks into the store very **fast** (or is moving fast on a mobility scooter) as the gate arm may not be fully open to the 90-degree position before they pass the gate bollard and there is not a lot we can do about this situation except increase the triggering distance – however Woolworths have clearly indicated that they do not want the radar triggering distance beyond **2m**.

In this instance the gate arm (not being fully open) may be a hindrance to the entering patron, the compromise here is to adjust the child safe potentiometer to max time delay by turning fully left thus allowing the ultrasonic child safe sensor max time delay before it triggers the gate bollard to a stop – hence we adjust max time (full left position) as a matter of course.

Important: store staff need to be advised that any object placed in (or close to) the arc of the gate arms may trigger the CSS and keep the gates in a stopped position indefinitely, until the object is removed.

To create an unobstructive store throughput the store manager should be informed that we recommended there should be no hand sanitizer units or baskets or any other displays etc. placed on the approaching walkway to the gate entry that would encourage the entering patron to **“stop”** before entering the store!

16. Check Woolworths's wiring configuration for gate arm LED colours:

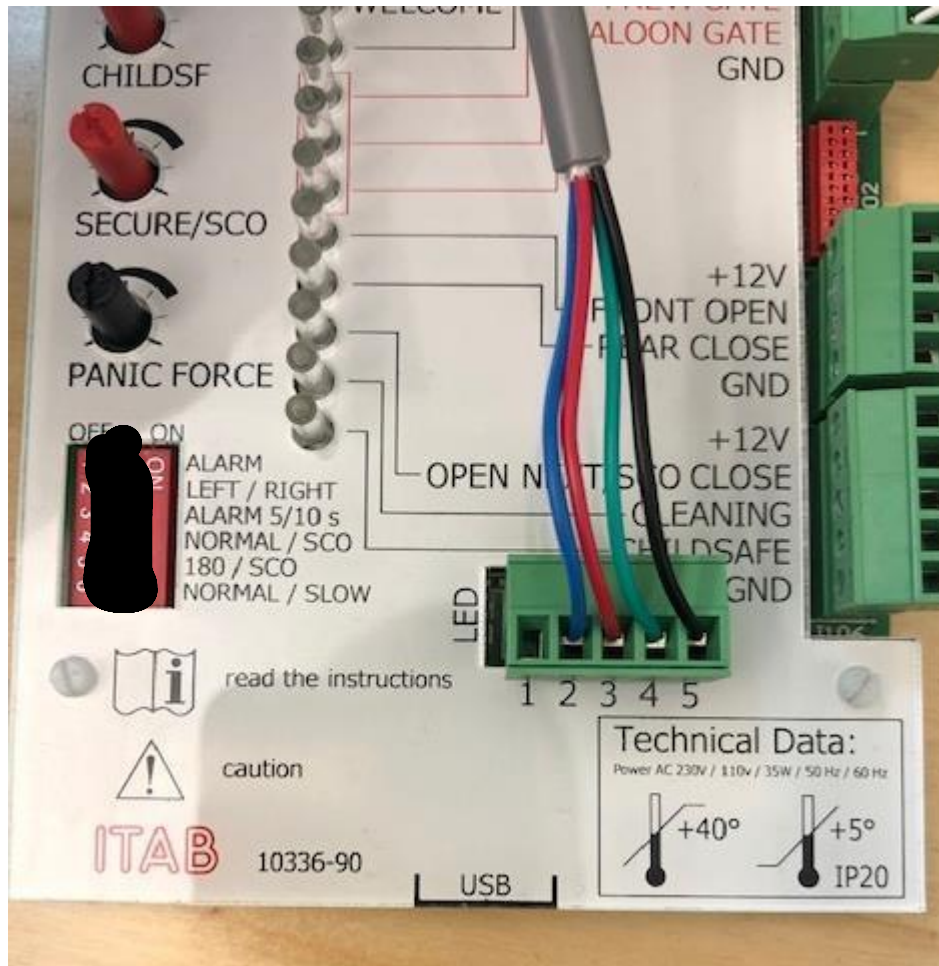

When connected as shown above the arms lights will operate to achieve the following LED colours for

Woolworths's operations:

PCB LED wiring colours:

1 = not used
2 = blue
3 = red
4 = green
5 = black

- Gate in normal closed operation = green lighting illumination
- Gate while in moving operations = green lighting illumination
- Gate pushed into break out (wrong way) operations = red lighting flashing illumination

17. Check gate arm assembly component breakdown.

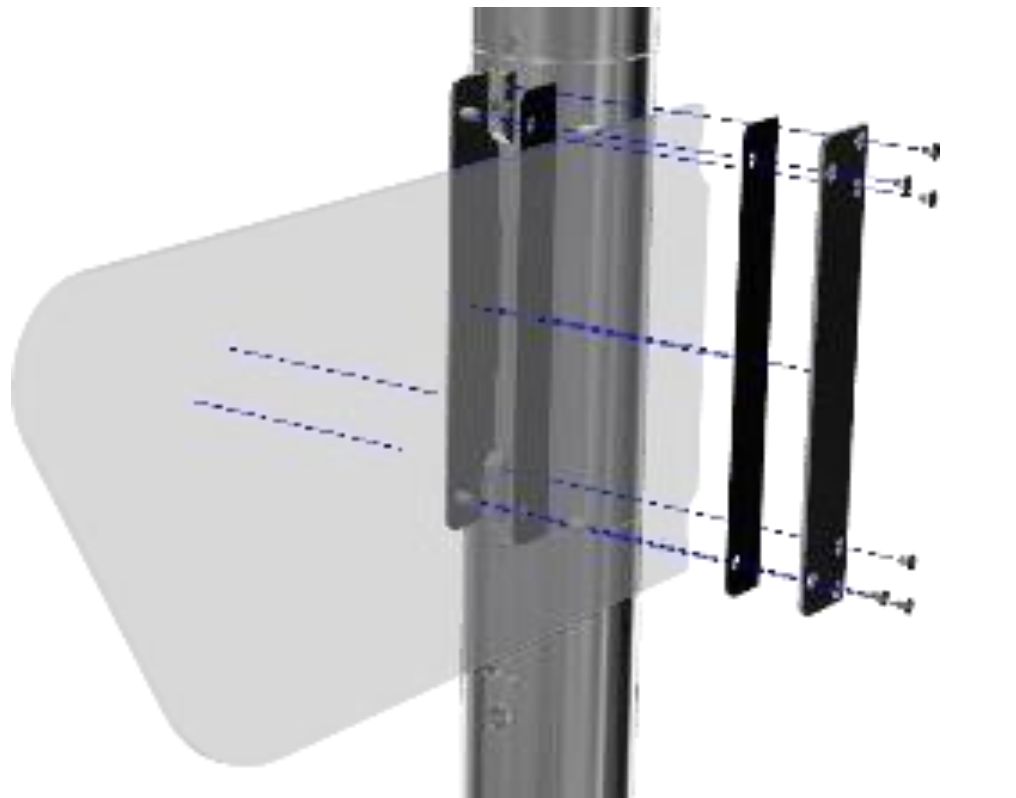

18. Check Approach radar triggering area box:

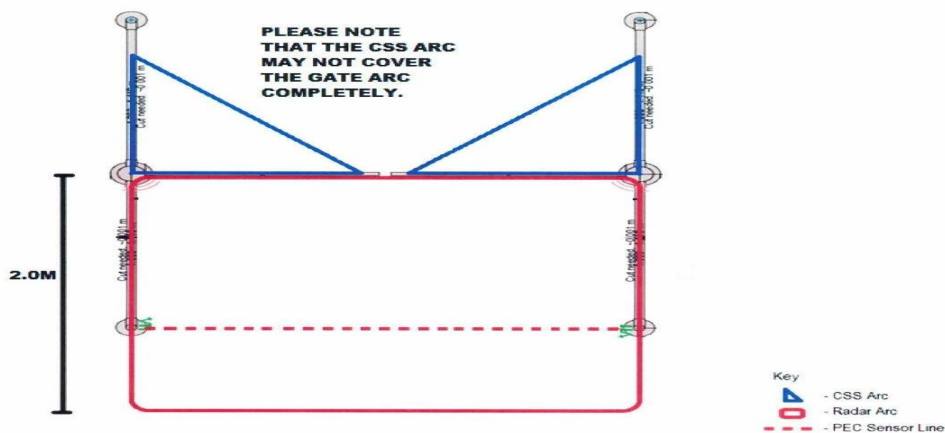

Complete the following quick tests:

- Blue markings behind the bollard (see image above) represents the pick-up area of the Child Safe Sensor (CSS). The alarm should sound when a person or object is within this blue area but **“only”** if the gate arms are in the fully closed position first – if the gate arms have started to open before a person or object enters this area the alarm will **not** usually sound – **test by stepping into the area.**
- Red markings in front of bollards represents the approach pick-up box of the radar approach sensor at 2m away. When a person steps into this approach area both gate bollards should immediately start driving into the store – note if either gate bollard have the CSS activated the radar will not trigger, therefore ensure the CSS arc is clear of any object or person during this test.

Test by placing an object in the area and **repeat the above test.**

- Radar adjustments should be made by checking radars trigger the gate bollard open within the 2m deep box (shown above) **without** the front PEC sensors in circuit.
PEC upright post sensors should be tested **without** the Radar sensors in circuit to ensure they are successfully (independently of gate bollard radars) triggering the gates open when the signal is broken by an entering patron - **test by temporarily disconnecting the radar.**

19. Check Woolworths Itab entry gate arms orientation image:



20. Check wiring link for audible alarm to trigger if gate arm arc has been penetrated:

Wire link to be terminated to OPEN NEXT/ SCO CLOSE & CHILDSAFE terminals.

Adding a cable link between OPEN NEXT/SCO CLOSE and CHILDSAFE will have the following effect on gate operation when the child safe sensor has been activated with the gates in the closed position.

- Child safe sensor will stop arm movement as normal
- Audible alarm now activates upon Child safe sensor activation
- Gate arms now flash red with alarm activation

Gates will flash red when the Child safe sensor has been activated while gates are in the open position as patrons enter the store. (please note audible alarm will not activate if gates have received an open trigger from radar sensors)

This function allows for the following: Patrons will be alerted not to exit via the welcome gates.

Staff will be alerted to objects being placed within Child safe zone

Delivers a clear indication of Child safe sensor activation

Please see photo indicating where wire link must be placed to achieve this function within the Child safe block connector located on the main PCB

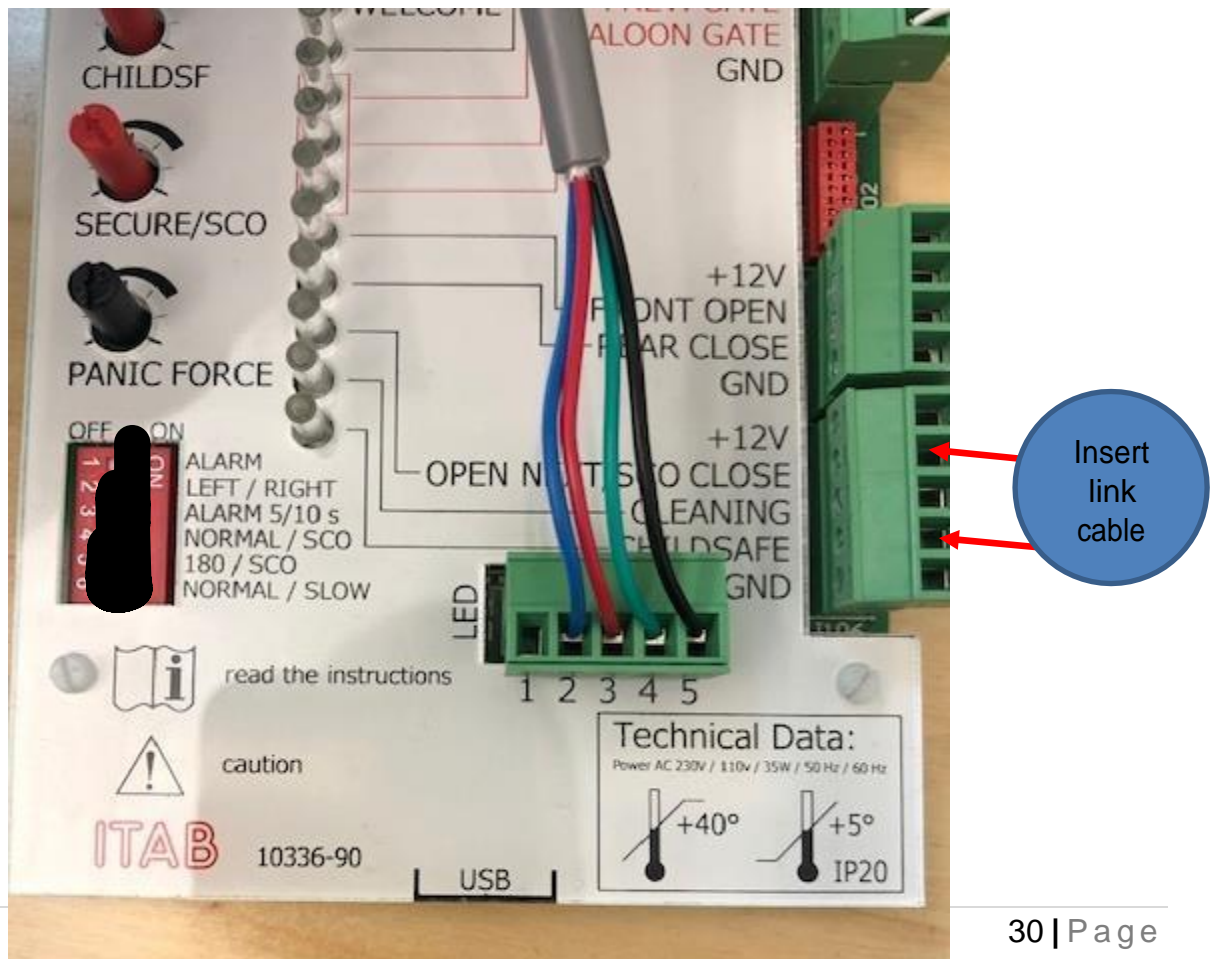

Item 21.

See separate sign-off checklist:

Woolworths Itab autogates K8 (Stockloss) installation checklist & sign off document (D. Casey July 14, 2021)			
Complete the following check list when installation is complete:			
	v	X	Manual
	Yes	No	Check
Site manager to check that gates are fully operational by ticking the boxes and signing below:			(Ref. item #)
Are final layout dimensions compliant , as per below drawing - measure gate layout?			Page 1
Are all gate arm LED colours operating compliantly (green for normal closed and opening - red for breakout position)?			16
Are all audible alarms compliant (sounding when arm is pushed in or out) with emergency breakout ?			12
Are audible alarms tested so as both alarms sound for 10 seconds (select left position on dip switch 3)?			12/20
Are both gate bollard radars individually tested to trigger gates open at 2.0 meters away from gate arms?			15
Are jointly-operated gate bollard radars tested to trigger gates open from (approx. 2.1 x 2.0 meter approach box area)?			15
Are gates operating as a saloon pair (either radar should trigger both arms open together) at the same time?			4
Are gates operating as a saloon pair (gate arms should close together 2 seconds after resting in opened fully position)?			4/13
Has operations been tested for delay of closing gate (beyond 2 seconds) if patron is still in the gate arm opening arc.?			13
Are gates tested to auto-reset after break out has occurred (test by pushing arms into the breakout position) ?			N/A
Are all gates bollards tested for strong resistance (adjustment from breakout force pot.) to avoid false alarming?			13
Are all gate bollards tested to identify to slow down for the approx. 10 degrees of opening arc.?			N/A
Are posts and cross rails aligned straight with gate bollards (stay within centre of guide rails at 90 degree to arms)?			6
Are there a minimum of 40 mm gap between gate arms when in the fully closed position?			Page 1
Are all gate arms straight and fully aligned (when doing adjustments avoid damaging the gate) with each other?			7
Are gate arm plastic spacers fitted into all gate arms (2 per gate)?			5
Are gate arms fitted with fully in tact rubber gaskets seperating the arms from metal brackets(2 per gate)?			5
Are gate arms fitted with all original matching fixing screws (12 per gate arm)?			17
Are gate bollards top covers fitted with original matching fixing screws (3 per bollard)?			N/A
Are gate bollard front cover plates fitted with original matching fixing screws (2 per bolard)?			N/A
Are gate bollard cups fitted with original matching grub screw (2 per cup) ?			N/A
Are all upright posts cups fitted with original matching grub screws (check all cups attached to post)?			N/A
Page 1/4			
Ensure the CSS units are operating correctly on both gate arms, independently:			
	v	X	Manual
Has the CSS been tested to ensure they prevent the arms from moving when someone steps into the gate arc signal?			Video
Has the CSS been tested to ensure they do trirringing signal does not overlap the other gate arms arc.?			Video
Has the CSS been tested to ensure they are not triggering before passing the bollards centre position on approach?			Video
Has the CSS been tested to ensure they are not triggering when a box is placed close up against the lead out rails?			Video
Other items:			
Has key operation been demonstrated to store staff (in case staff needs to be isolated gate bollards to remain open)?			N/A
Has decomissioned equipment been handed back to site manager (technician to take photo) ?			N/A
Please confirm the following photos and videos of the works have be sent to Woolworths with this checklist:			
Photos showing the gate open and closed from inside store ?			N/A
Photos showing the gate open and closed from outside store ?			N/A
Photos showing the gate panel alignment when in an open and closed position?			N/A
Photos showing the use of the gate arm, rubber gasgets , sleeve on both gate panels?			N/A
Photos showing the use of the plastic spacer on the gate panels?			N/A
Photos showing that there are no screws missing on the arm fixing brackets?			N/A
Videos validating gates operations:			
Videos showing the gates operate when objects are placed against the railing on both sides?			N/A
Videos showing the blind spot in the centre of the gate area?			N/A
Videos showing that the front sensors are triggered at a distance of 2 M?			N/A
Follow up works required:			
Are you satisfied that the finished works are compliant and the layout is suitable to preform its intended operations?			N/A
Are there ground work fixings follow up required?			N/A
Are there any screws or rubber/plastic bungs needing replacing ?			N/A
Are there any covers needing replacing ?			N/A
Are there any keys needed to be supplied to the store?			N/A
Is there any equipment left behind for Woolworths perusal (if yes please was the store manager notified of location)?			N/A
Page 2/4			

Item 22.

Sensor adjustments video QR code.

<https://youtu.be/lmyngCrtN0s>

