

Radford.

Installation Manual

Prepared by Dominic Casey for
Woolworths

(01/11/2021)

Revision 2.1

Woolworths Itab Alphagate
Kit 3 manual

The aim of kit 3 and associated manual is to convert a Phase 1 U/G (upgrade) welcome gate assembly to a new type kit 7 assembly with new lead in rails including sensors and reflectors. Before commencing work onsite please see drawings and images below. Please take note that the existing phase 1 U/G gate assembly with associated rails and end posts will need to be integrated into the new components of kit 3 to complete the installation. Kit 3 will be installed at the front of the existing welcome gate assembly. The gate assembly may need to be moved to allow extra components to be installed. Please check with builder/architect on site before commencing work.

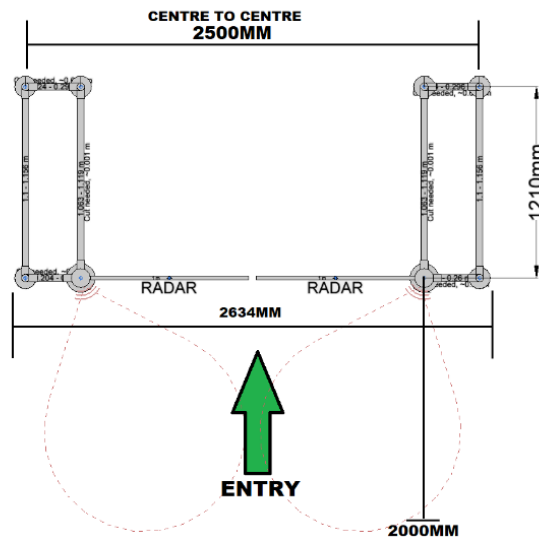

Existing phase 1 upgrade

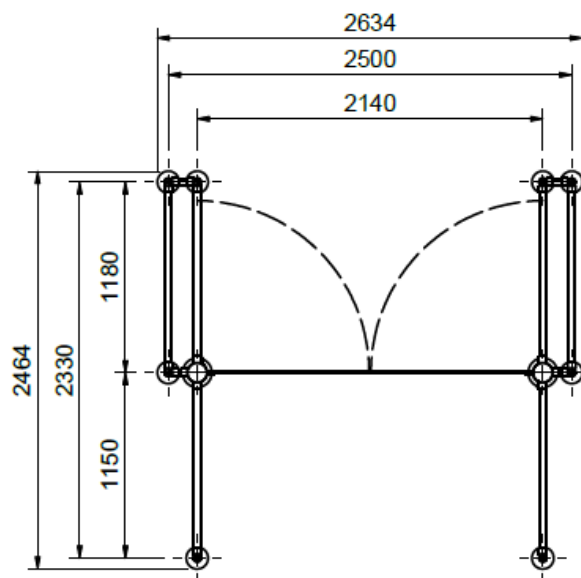

Finished kit 7 after applying kit 3 components

The existing welcome gate assembly must be carefully removed as parts from this gate kit are used in new gate

- Isolate power supply
- Remove gate arms
- Remove lower PCB cover on gate bollards.
- Ensure power and data cables are disconnected from the gate bollard PCB taking care not to damage cables.
- Loosen all grub screws securing rails in place.
- Remove upright rails.
- Remove cross rails.
- Remove gate bollards.

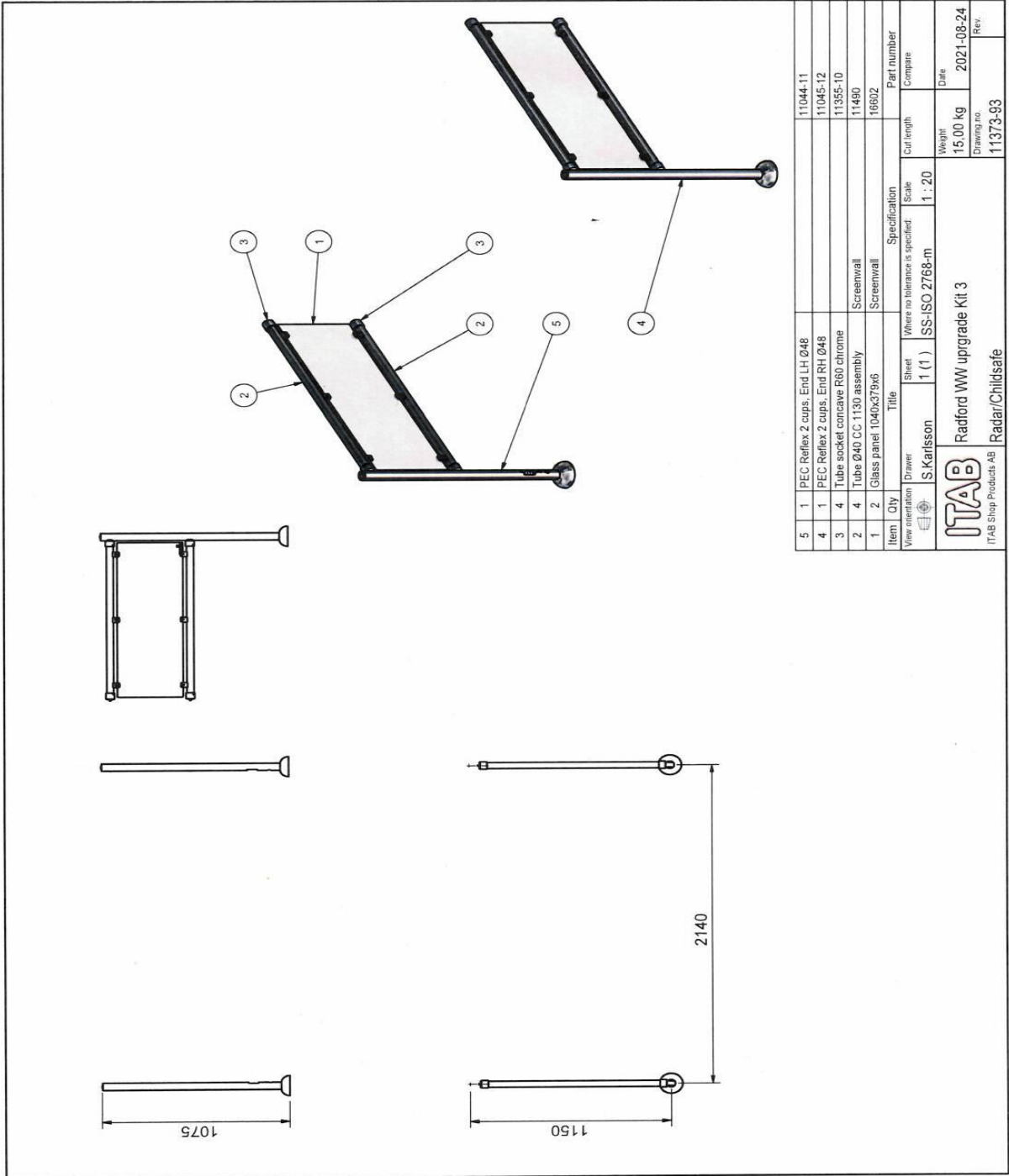

PROPRIETARY AND CONFIDENTIAL. The information contained in this drawing is the sole property of ITAB Shop Products AB with corporate number 56132-406, a company within ITAB Group. Any reproduction or use in part or as a whole without the written permission of ITAB Shop Products AB is prohibited. The drawing shall be returned to ITAB Shop Products AB immediately upon request.

ALL MATERIALS MUST BE RoHS COMPLIANT

Kit 3 components

Woolworths Kit 7 (Phase 3) Itab autogate installation and commissioning Manual

(Created by Dominic Casey - Radford Retail Solutions P/L, dated: 09/07/2021)

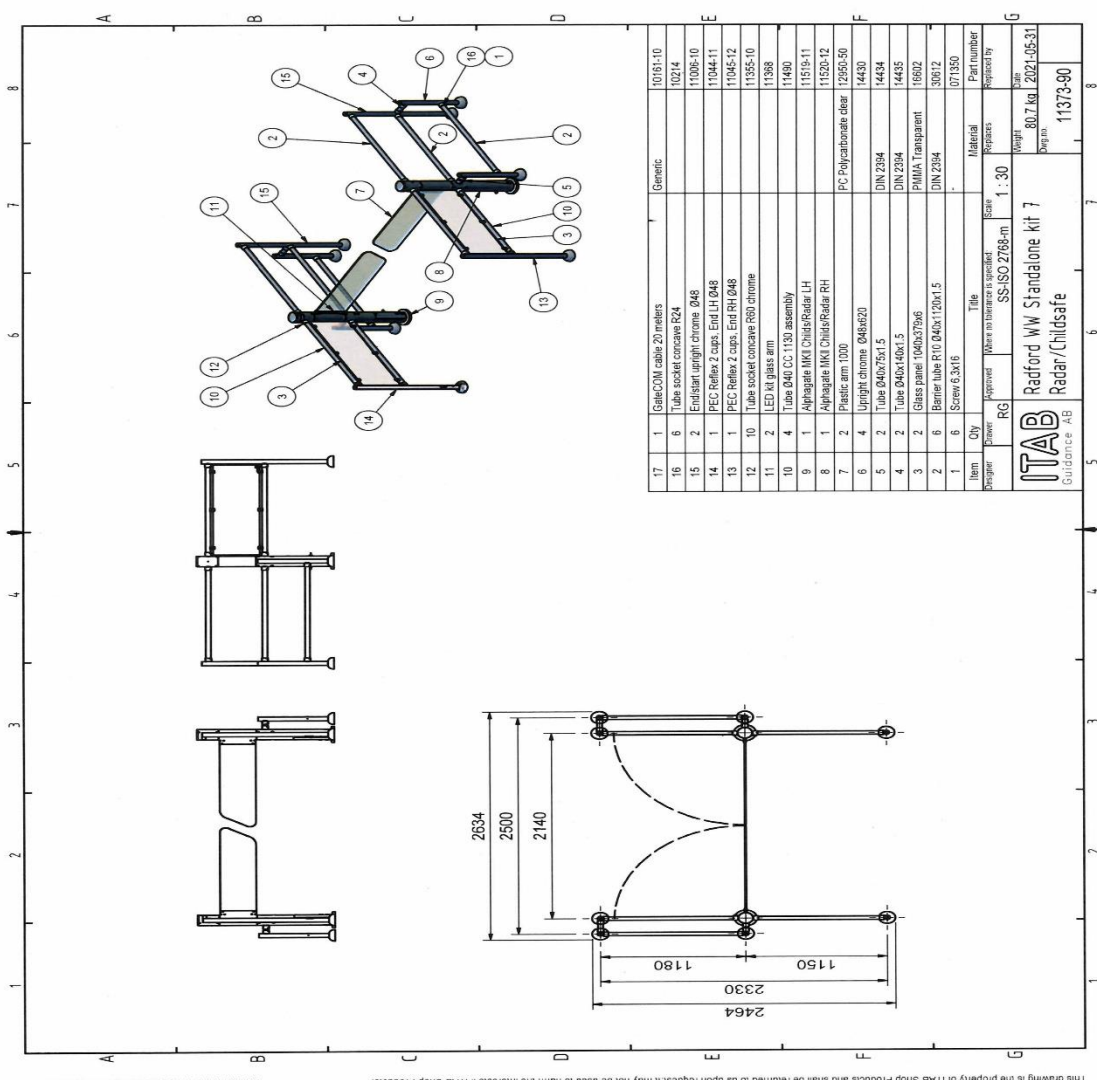

| Item | Qty | Desc | Material | Part Number |
|------|-----|--------------------------------|------------------------|-------------|
| 17 | 1 | GalvCOIL cable 20 meters | Generic | 10161-10 |
| 16 | 6 | Tube socket concave R24 | | 10214 |
| 15 | 2 | End/start upright chrome Q48 | | 11006-10 |
| 14 | 1 | PEC Reflex 2 caps. End LH Q48 | | 11044-11 |
| 13 | 1 | PEC Reflex 2 caps. End RH Q48 | | 11045-12 |
| 12 | 10 | Tube socket concave R80 chrome | | 11595-10 |
| 11 | 2 | LED XL glass arm | | 11368 |
| 10 | 4 | Tube Q40 CC 1130 assembly | | 11480 |
| 9 | 1 | Alphagate MM Childs/Radlar LH | | 11509-11 |
| 8 | 1 | Alphagate MM Childs/Radlar RH | | 11509-12 |
| 7 | 2 | Plastic arm 1000 | PC Polycarbonate clear | 12959-50 |
| 6 | 4 | Upright chrome Q48x20 | | 4430 |
| 5 | 2 | Tube Q40x75x1.5 | DIN 2394 | 4434 |
| 4 | 2 | Tube Q40x140x1.5 | DIN 2394 | 4435 |
| 3 | 2 | Glass panel 1040x379x6 | PMMA Transparent | 16602 |
| 2 | 6 | Bearer tube F10.040x120x1.5 | DIN 2384 | 38612 |
| 1 | 8 | Screw 6.3x16 | | 071530 |

This drawing is the property of ITAB Shop Products and shall be returned to us upon request. It may not be used to harm the interests of ITAB Shop Products. ALL MATERIAL MUST BE ROHS COMPLIANT

| | |
|---|--|
| ITAB Guidance AB Radford WW Standalone kit 7 Radlar/Childsafe | Scale 1:30 Weight 80.7 kg Drawn 2021-05-31 Part Number 11373-90 |
|---|--|

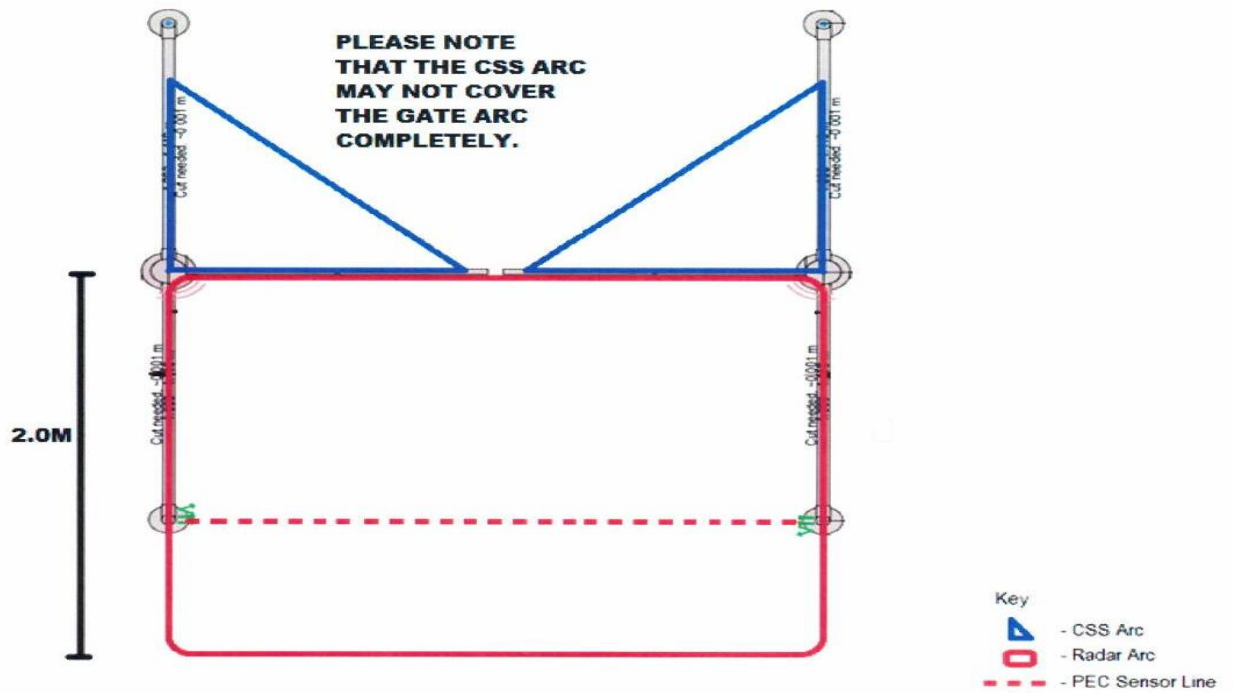

STORE ENTRY

Woolworths kit 7 (Phase 3) Itab autogate manual contents:

Follow the installation steps as per items 1 to 20 listed below:

Item 1. Unpack materials from carton and ensure all components are fully intact.

Item 2. Layout the bollard and posts as per above drawing and confirm measurements with site foreman ensuring all contents are accounted for. Precise measuring is required to ensure square alignment.

Item 3. Drill floors fixing and fit gate bollards only, firmly into the ground to begin with – confirm fixings to be used with site building manager.

Item 4. Terminate synchronisation cable connections between gate bollards.

Item 5. Fit polycarbonate arms to Woolworths Itab Alphagates.

Item 6. Fit rear lead-out post and rails inc. low-level outer protector rail system.

Item 7. CSS device may have already been fitted to the gate bollards, if not fit same.

Item 8. Fit new type radar sensor cover-strip (if supplied) before CSS commissioning commencement.

Item 9. Wire CSS audible alarm link.

Item 10. Install lead in upright post and rails incorporating the photocell eye (PEC).

Item 11. Set up dip switches on the controller board.

Item 12. Set up and commission master & slave function in gate bollards to operate as a saloon couple.

Item 13. Set up & commission PCB controller timing.

Item 14. Set up & commission sensors.

Item 15. Check Woolworths's wiring configuration for gate arm LED colours.

Item 16. Check gate arm assembly component breakdown.

Item 17. Check approach radar triggering area box complies.

Item 18. Check Woolworths Itab entry gate arms orientation image.

Item 19. Check Wiring link for audible alarm triggers if gate arm arc area is penetrated.

Item 20. Complete separate sign-off checklist.

(Note: as extra fittings are usually supplied with kits it is common to have left over components)

1. Unpack materials from carton and ensure all components are accounted for and fully intact.

See Bill of Materials on page 1, complete with drawing of gate layout.

2. Layout the bollard and posts as per above drawing and confirm measurements with site foreman.

Once measurements are confirmed, mark out drilling points and floor chase line before moving equipment away for drilling and floor chasing.

Important considerations:

- Drill holes into the ground and fit both bollards **before** drilling the fixing holes for the upright lead in sensor posts or the lead out rail upright posts, then complete floor chasing for power and synchronisation cabling – use 90-degree conduit elbows to allow cables to penetrate through the **centre** of large centre cut-out in base plate.
- 10 -amp power is required for each gate bollard (centre to centre of bollard usually via underground) see below fixing plate dimensions. Power terminations at **bottom** of gate bollard only – gate may be severely **damaged** by running power cables through the gate bollard!
- A synchronization cable is required between both gate bollards (centre to centre of bollard usually via underground). Care should be taken not to damage cables when fixing bollards to the ground – sync. cable may be installed into the same floor-chase, separated by protective conduit.

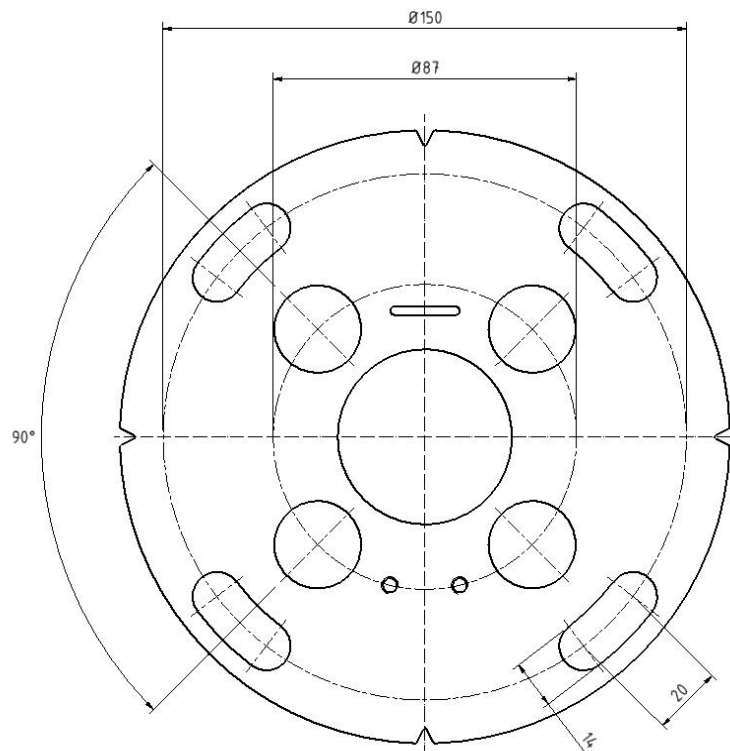

Adequate fixings penetrating, at least 75mm **into** the floor, with flat washers and spring washers are recommended (builder or Architect to nominate fixings). If floor concrete is inadequate for standard fixings Chemset-bolt solution or similar should now be used to repair any loose bolts.

3. Drill floors fixing and fit gate bollards-only firmly into the ground, to begin with.

After studying item 2 above in detail, bolt gate bollards firmly into place ensuring they are installed in an aligned position, as practicable.

4. Terminate synchronisation cable connections between gate bollards:

Saloon and ground to be connected to both facing gate BOLLARD controllers, via saloon & GND.

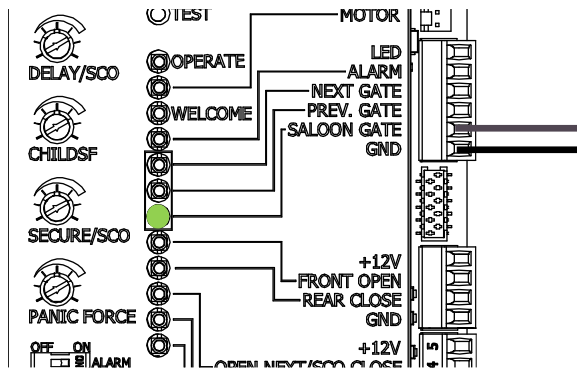

5. Fit polycarbonate arms to Woolworths Itab Alphagates

Before power is connected to gates you must fully understand the following information below before attempting to fit the gate arms, otherwise the equipment may be severely damaged:



It is very important to make sure that ALL components are fitted to the gate arm bracket correctly before placing the polycarbonate arm into the metal bracketry, otherwise breakage is likely to occur either on the spot or later during normal operations.



Ensure the rubber gaskets (there are two, one each side of the gate arm panel) are fitted correctly – no arm materials should come into direct contact with metal components at any time.



Ensure **BOTH** plastic spacers are fully intact and firmly in place on metal mounting shaft – the gate arm should not come into direct contact with metal components at any time.



Ensure no cables associated with LED lighting strip are **not** damaged before fitting (and during fitting) of gate arm panels.



Arms should be placed with equal spacing (there should always be a minimum of 100mm for safety reasons) between gate arm panels ends, which are fitted with a sloping offset design – see item 17 below.



All fixing screws should have **thread lock** applied to their ends before final tightening - ensuring they are firmly countersunk flush into outside-metal fixing panel.



Remove ALL gate arm protective coverings including the section that is inserted into fixing bracket as this may reduce the LED visibility of the gate arm lighting.



Carefully fit new arms ensuring all fixings, spacers and rubber gaskets are correctly and firmly fitted into their place before inserting fixing screws.



Do not tighten gate bollard cross rail cups or upright post cups set screws until gate arm panels are fully installed into fixing brackets and fully aligned into the 90-degree position below the cross rails – this allows for a more flexible gate arm alignment when in the **fully opened** position.



When fitting gate arms into their brackets, ensure the (2 per gate bollard) plastic buckets spacers are in place (**making sure there are no direct metal bracketry to gate arm contact**) and are fully inserted into the (2 gaskets per gate bollard) rubber gaskets which sandwiches the arm and in turn separates the gate arm panels from the metal brackets.

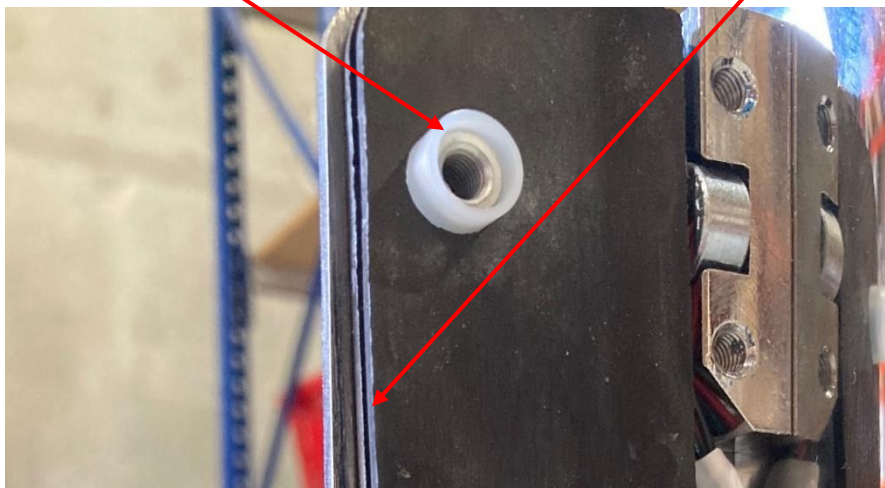



Gently tighten gate arm bracket screws until the plastic spacer flattens up tight to the polycarbonate arm panel. Make sure check that the rubber gasket and plastic spacers are not overlapping each other, and all components are aligned correctly before firmly tightening all gate arm fixings in place.



Please note operating the gates with loose gate arm-fixings, missing screws or missing rubber seals will damage the arms over a very-short period of time.

(Important: replace or report any missing screws or caps when completing checklist)

6. Fit rear lead-out post and rails:

Drill ground penetrations and fit rear (lead-out) post & rails firmly into the ground ensuring the gate arms will fit directly under the **centre** of the cross rail when opened fully.

When happy that the gate arms can be aligned with lead out rails (all squared up and fully opened arms sitting directly under cross rail) carefully measure, mark out drilling points, drill and fix outer protector rail system.

Powering up the gate bollards at this point will allow you to achieve arm alignment more accurately. Important make sure **NO** sensors are fitted to the gate bollards when you do this.

With the gate bollards are powered up with **no input sensors connected** the gates should power into the normally closed position – before taken the next steps ensure dip switches as per below:

> go to **left-hand** gate bollard PCB and ensure the # 2 gate dip switch is flicked to **left**.

> go to **right-hand** gate bollard PCB and ensure the # 2 gate dip switch is flicked to **right**.

> adjust the gate arms to a centralised position - see gate arm alignment instructions below:

The gate bollards will be **severely** damaged if you do not strictly understand and follow the gate arm adjustment process, which starts by making sure you understand “**why**” you need to remove all sensor inputs before you attempt to adjust fully open position of the gate bollard arm.

To assist with the gate arm alignment (ensuring the gate arm panel sits under the rear top cross rail) commission newly installed gate arms as per arm alignment/adjustment process listed directly below:

Disconnect all radar, PEC and CSS sensors completely to ensure there are no sensors in circuit while the Allen key adjuster tool is inserted in the coulisse (*electronic encoder circuit/position sensor*) otherwise, if the sensor is in circuit, they may trigger the motor to activate with the tool still in place and this tool will move with the shaft and jam against the metal casing (see image of gate cut out for Allen key adjustments below) – **ignoring this cautionary measure may severely damage the coulisse beyond repair and void warranty completely.**

Radford.

If the gate arm needs to be adjusted for alignment (providing you are sure there are no sensors in circuit), loosen the locking screw that holds the coulisse (electronic encoder circuit/position sensor as shown in the image below) with 3mm Allen key and move the coulisse a little bit to the left or to the right depending on how the gate arm needs to be adjusted.

Move adjustment tool slowly and carefully as **small** movements are enough to adjust the gate arm several centimetres. When the gate arm is satisfactory adjusted, fasten the locking screw again – do not over tighten the locking screw.

To be able to do this adjustment successfully the power needs to be switched **on** (with the key) to the gate bollards, again you must always make sure **no** sensors are in circuit throughout this whole adjustment process otherwise you may damage the coulisse beyond repair and void warranty.

Move Allen Key to the right
→ gate arm moves to the left.

Move Allen Key to the left
→ gate arm moves to the right.

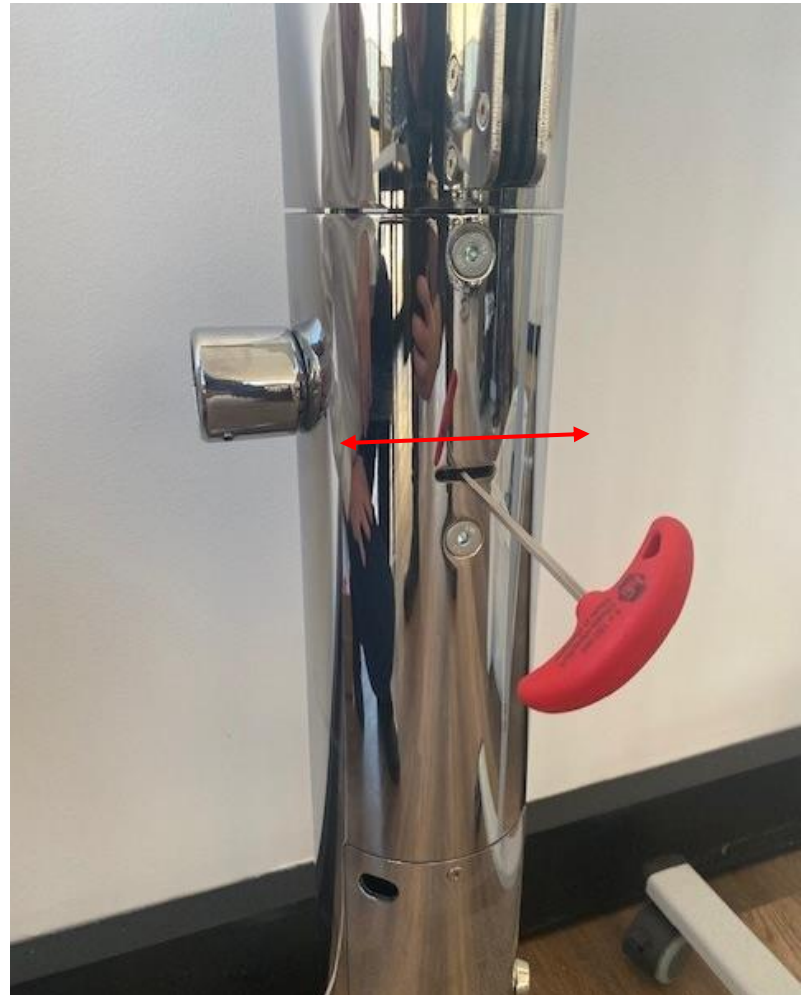

By this point you should now have both gates bollard arms facing each other aligned straight.

With the synchronisation cable terminated between saloon & GND on both gates now insert a temporary wire link on one gate bollard between cleaning & GND.

With the temporary link wire in place and the gate powered on at the key switch this should open both gates to the fully opened 90-degree position, thus allowing you to align your lead-out posts and rails with the fully opened arms ensuring the gate arms sits directly under the centre of the cross-rail position **before** you drill the ground fixing points of the upright posts.

Important: remember to remove wire link when finished.

7. Check the CSS device have already been fitted to the gate bollards.

In some circumstances CSS kits may be supplied separately and will require onsite fitting – see kit contents and installation position images below.

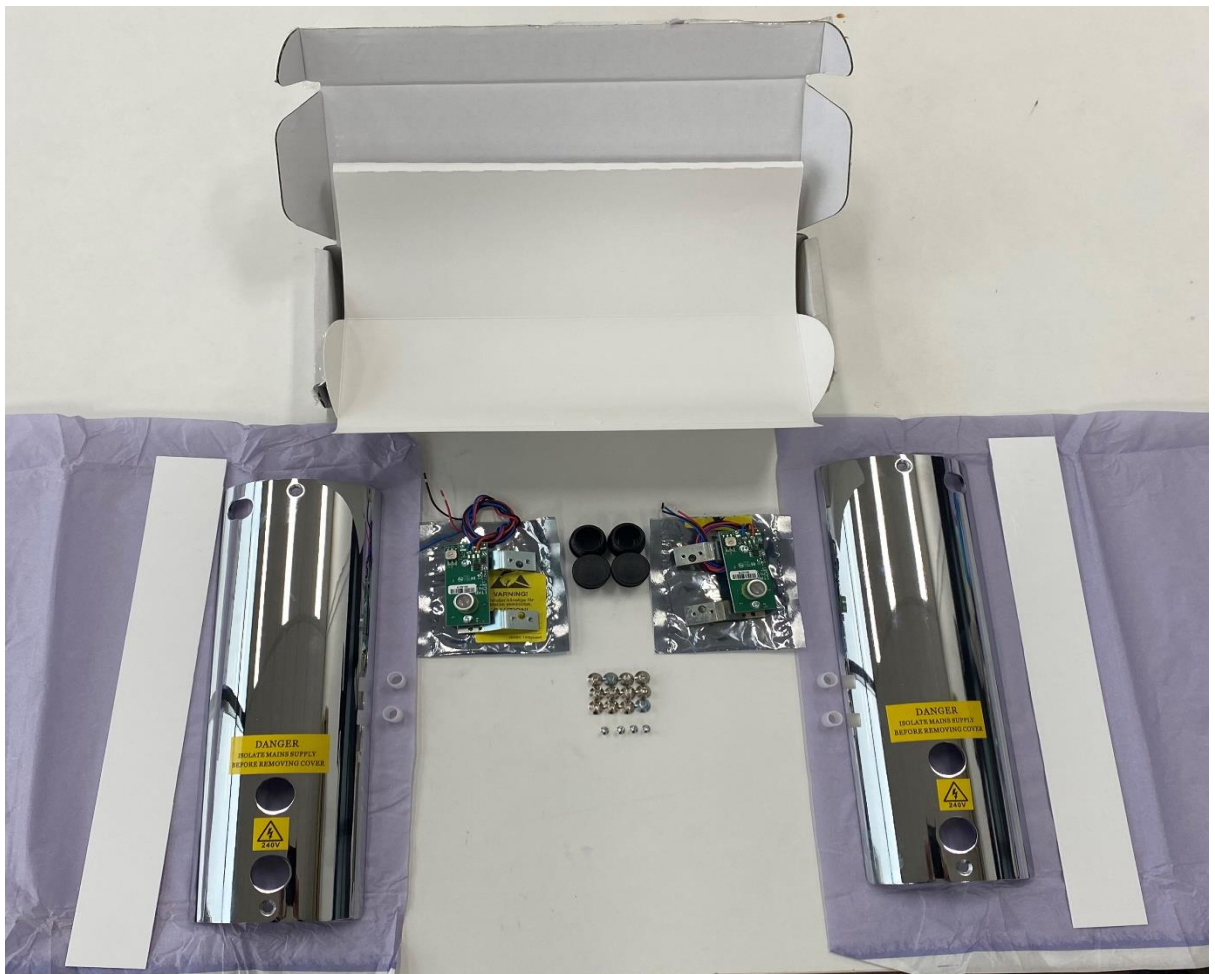



Note there are left and right-hand fixing brackets for individual gate bollards.

Child safe sensors are ultrasonic sensors that are used as a safety device to help protect patrons from encountering the moving gate arm. The ultrasonic sensor is a presence sensor designed to detect the presence of a person in the area behind the gate where the gate arm rotates.

It is very important that there are no obstacles within the detection area, for example it is important that uprights posts are installed at the correct length away from the gate bollards, so as the sensor **does not** detect the actual upright posts – make sure CSS are fully tested as per checklist upon installation completion.

CSS wiring terminations to autogate controller should be checked for completeness:

Red = + 12 V

Black = GND

Blue = Child safe (signal)

Final sensors testing can only be assured when covers are fitted back onto bollard and the radars sensors have been fully commissioned (see item 13)

Caution:

- Please make sure there are no-loose fixings on the child safe bracketry as this will produce false triggering.
- The store manager needs to be advised **not** to place baskets, shopping carts or any other objects close to the child safe sensor detection area behind the gate arm otherwise gates will stay in the open position.
- Please make sure there are no wires or objects blocking the front of the child safe sensors as this will produce false triggering.
- Please be careful of the sensor on the CSS device as this is a sensitive part and can be

easily damaged while installing, particularly when **removing** and **refitting** the gate bollard front cover plate.

Important: the front cover metal case should **not-touch** the metal casing of the sensor assembly (see below image) – if adjustment needed, gently bend the fixing bracket with pliers as required.



8. **Fit new type radar sensor cover-strip (if supplied) before CSS commissioning commencement.**



(Radar cover slides in & out without fixings cover to join to the side away from gate bollard cut out)

9. Wire CSS audible alarm link:

Fit permanent link wire between “open next and CSS (see item 18 image on page 24 below.) This will enable audible alarm to sound if a patron or object is within the gate arm opening area.

Note: this alarm operates only when the gates are in the fully closed position **before** you enter the detection arc.

10. Install lead in upright post and rails, incorporating the photocell eye (PEC):

Align upright posts at 90 degrees to gate arms mark floor fixings, remove posts and drill floor fixings holes. Fit posts and rails as straight as possible with the rest of the layout ensuring the PEC and reflector posts are fully aligned with each other. When satisfied post & rails are squarely aligned, fit glass infill panels, ensuring the plastic spacers (separating glass from metal) for fitted firmly in place.

Wire up PEC:

PEC cables can be fed through the cross rail and into the gate bollard by drilling through the inside of the cup while cup is attached to the gate bollard and upright post as required.

The PEC should be connected as shown in the image below:

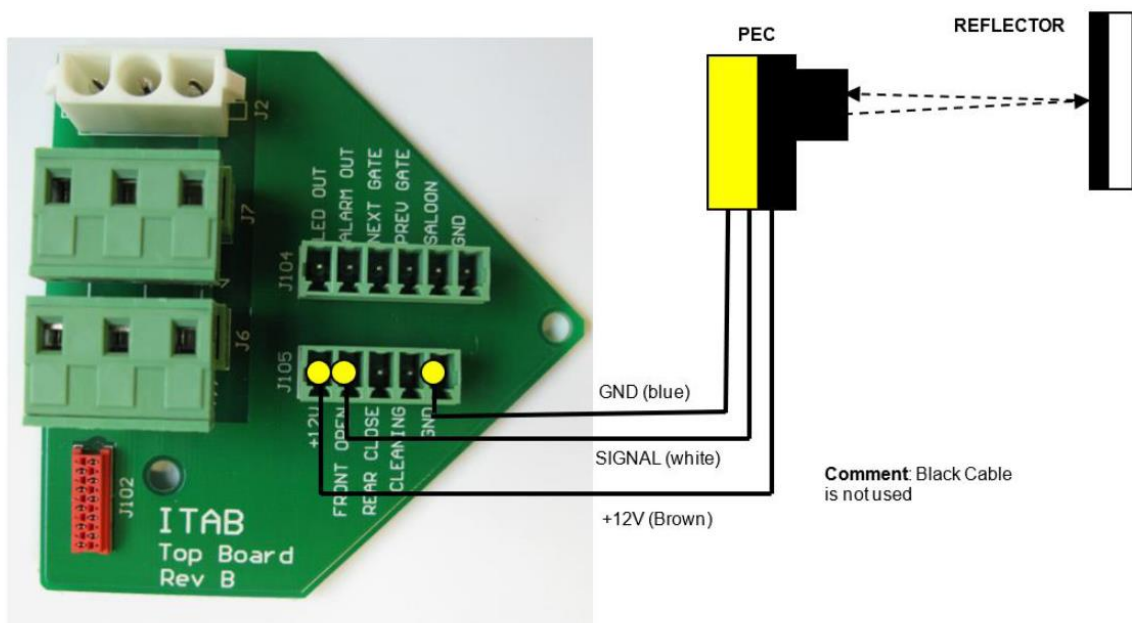

In a photocell eye system, the gate opens when an object breaks the infrared beam, and closes automatically after a set period, once the object has been cleared from the beam – this period of time is adjustable by adjusting the right hand (Master) gate bollard Delay/SCO potentiometer on controller PCB.

When setting up the PEC, the open time delay should be set to "min position" (anti-clockwise) on the time delay potentiometer (top pot) on the control board located at the base of the bollard. Adjustment and commissioning of the sensors to be done later (see items 11& 13 below).

11. Set up dip switches on the controller board:

Set up dip switches in each gate bollard, as per its installed position.
(upon entry to store, the gate on your left is considered a left-hand gate & the gate on your right is considered right-hand gate)

Dip switch block settings on both **left & right-hand** gate bollards:

- 1 = right position
- 2 = left **or** right position (left hand gate = select left) (right hand gate = select right)
- 3 = Right position
- 4 = left position
- 5 = left position
- 6 = left position

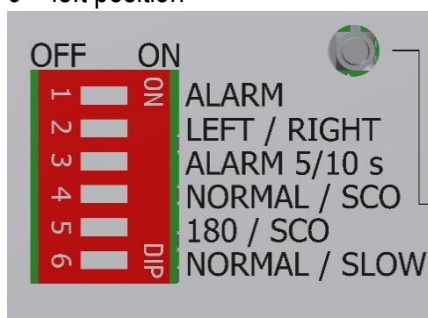

12. Set up & commission master & slave function in gate bollards to operate as a saloon couple – see potentiometers on main controller:

Left-hand gate (Slave)

- Set DELAY/SCO and SECURE/SCO potentiometers to maximum: (fully to the right-hand position).
- Set CHILDF potentiometer to minimum: (fully to left hand position)

Right hand gate (Master)

- Set DELAY/SCO potentiometer to full left and then approx. 25% of its full range to the right position, as a starter point, before final timing adjustments are made later.
- Set CHILDF and Secure/SCO potentiometer minimum: (fully to left hand position)

Check that the gate synchronization cable is correctly connected between both gates (saloon to saloon and GND to GND) this then ensures the gate couple will be controlled as

one-unit and **all** adjustments made to the **right-hand** controller delay timer will control both right and left-hand gates alike.

(Note: right-hand gate is set up as the master & left-hand gate is set as the slave)

Double-check final settings for PCB potentiometers as per below, before commissioning gates:



DELAY/SCO

(Left hand gate)

← Set fully to right position (to set up master & slave function)



CHILDSF

← Set fully to left position (to ensure CSS min. reset time)



SECURE/SCO

← Set fully to right position (to set up master & slave function)



PANIC FORCE

← Set to mid position (to ensure gate arm break out force is moderate)

(Right hand gate)



DELAY/SCO

← Set fully to left, then adjust slightly to the right "if required" for a 2 second delay.



CHILDSF

← Set fully to left position (to ensure CSS min. reset time)



SECURE/SCO

← Set fully to left position (to set up master & slave function)



PANIC FORCE

← Set to mid position (to ensure gate arm break out force is moderate)

13. Set up & commission controller timing on PCB:

- Remove the lid on top of **each** gate bollard and **disconnect** the radar electrical connectors on **both** gate bollards to (**temporarily**) render the radars out of circuit. Then power up gates and press the test button on the master gate (right hand gate) and both gates should now operate as a saloon-gate couple (**both gates should open and close at the same time – ensure PEC sensors are not blocked during this test**).

After the test button depressed as per above, the gate couple (both left and right-hand gates) should open **into** the store, stopping in the 90-degree (fully open) position and remain open for a pre-set time before driving back to the fully closed position.

- Real-life time delay can be tested later by triggering radars during radar set up step during commissioning. (Time delay potentiometer will adjust this timing - remembering left is least).
- The time-lapse (time gates remain fully open) for both gate bollards can now be adjusted by the master (right-hand) gate DELAY/SCO potentiometer whereby both gates should operate and close at the same time - the recommended time delay (time-lapse) between the gates **after** they have **reached** the fully opened position and the time the gates **start** to drive back to the closed position should be approx. two (2) seconds. This time delay setting can only be successfully adjusted after the sensors have been refitted.
- Adjust panic force potentiometer (break out function) by winding full left (off) position and then wind to the full right before setting to the (approx. the 75% position) final position.

This above final setting will produce a **moderate** breakout force required to push out the gate in the event of an emergency.

Caution: if breakout force is not adjusted sufficiently, the gate will regularly false alarm!

Notes:

- A. In normal operations the gate arm drives to the open position, at the last 10 to 15 degrees the gate arm slows down before coming to a full stop at the 90-degree position - this is a normal design feature design to reduce the impact when the gate arm mechanism meets its mechanical stops in the fully open position.
- B. Breakout adjustments may be required (force increased) to help reduce excessive arm movements when the gate arm reaches the fully stopped position.

14. Set up & commission sensors:

Commissioning and adjustments **cannot** be completed successfully without having full access to the store with the entry roller shutter fully in the **open** position, as in a real-time situation.

****See video link below before commissioning of sensor – QR code also**

<https://youtu.be/lmyngCrtN0s>

Recommended sensor adjustments sequence:

Adjust the sensors in order starting with **A**, then **B**, then **C** as per listed below.

A. Radar should be adjustments to detect approaching patron from 2m away:

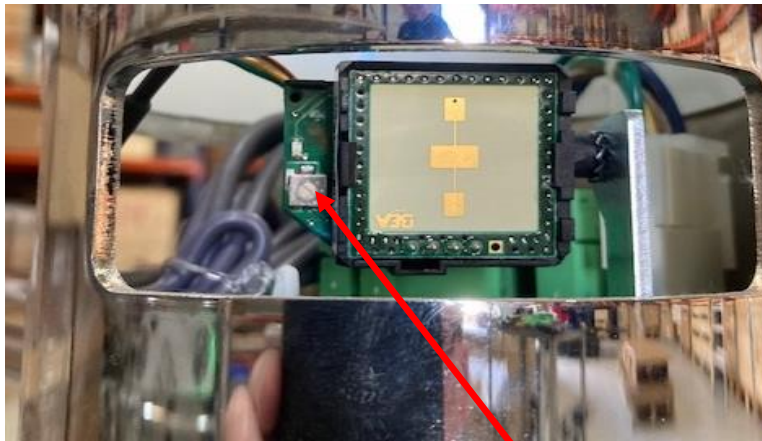

There are 3 radar adjustments as follows:

1. = left or right adjustments as per Allen key bollard fixing screw
2. = up and down as per side radar bracket fixing screw
3. = pick up distance as per potentiometer adjustment on radar device

Both gates in the saloon-gate couple are fitted with radar controllers (either gate bollard radar will trigger the gate couple) to trigger the gate-couple as one unit.

- Connect the electrical connectors back onto the radar units and adjust the mechanical radar bracket on **each** gate into position - the radars should be pointing in the general forward position and slightly into the middle of the gate arms centre. Radar should also be pointing **slightly** down towards the floor to pick up shopping trolley wheels as a trolley approach and to avoid ghost signals being picked up from above.

- Remove the inner white plastic radar cut-out cover (slides out by hand) and adjust the radar approach sensor triggering distance potentiometer on the top of radar sensor to the full left-hand (off) position, then adjust in small increments to the right until the gate radar is picking up a forward **moving** person or object at 2m, measured from the gate arm.
- Disconnect **each** radar electrical connector (one at a time) and test the remaining in-circuit radar sensor distance picks up a trigger signal from 2m from the gate bollard and opens both gates fully – each individual gate bollards radar sensor should pick up approaching patrons across the full width of the arm and include a little overlap to the other arm position.
- Ensure electrical connectors are re-connected firmly into both radar units and ensure cables are secured with a cable-tie to prevent false triggering. Please also note that **loose** radar brackets (or gate bollards fixings) will cause **false** triggering.

B. CSS Commissioning:

Ideally the CSS detection arc should be the same length as the gate arm, however this is not always possible (as ultrasonic sensor range are sensitive and device adjustment varies slightly from site to site and from device to device).

It is recommended to set as large a CSS detection arc as possible, the larger the protection arc the safer the entrance will be.

To adjust the range for the CSS detection arc, turn the potentiometer clockwise to increase the detection area and anti-clockwise to reduce the detection area – see chart below.

The Woolworths arm size in this instance is 1000mm long and as per the below chart the number 5 should be selected first as this matches the 1000mm range to begin with.

Please note, due to site and device differences the number 5 is the **starting point** only for commissioning purposes – further adjustments up or down are usually required.

In most cases you will not achieve full ultrasonic coverage behind the entire gate arms arc and a compromise will need to be established.

Each gate arm operates independently - consider the following example: if say the left gate arm arc has more CSS coverage than its own gate arm length (too much coverage) it may detect beyond the length of its gate arm and detect the presence of the opposite gate arm, this in turn will wrongly stop the gate from operating. ***(The compromise will be to reduce the range back to usually less than the gate arm length, rendering a small area between both gate arm ends with no detection at all)***

During normal operations, a patron would approach the gates at average walking speed whereby the radar would pick them up at a triggering distance of **2m** away – as itemised in checklist test.

In this situation (triggering the radar at **2m**) the gates would usually be fully open **before** an approaching patron passes the gate bollards (remember the radar produces a continues triggering signal to open the

bollard so long as the patron keeps moving towards the gate bollard) therefore as the patron steps into the **rear** gate arm arc its presence will trigger the CSS ultrasonic sensor to keep the gate arm open (regardless of how slow a patron might be) until the entering patron is almost into the store.

Note, there may be an issue if a patron walks into the store very **fast** (or is moving fast on a mobility scooter) as the gate arm may not be fully open to the 90-degree position before they pass the gate bollard and there is not a lot we can do about this situation except increase the triggering distance – however Woolworths have clearly indicated that they do not want the radar triggering distance beyond **2m**.

In this instance the gate arm (not being fully open) may be a hindrance to the entering patron, the compromise here is to adjust the child safe potentiometer to max time delay by turning fully left thus allowing the ultrasonic child safe sensor max time delay before it triggers the gate bollard to a stop – hence we adjust max time (full left position) as a matter of course.

Important: store staff need to be advised that any object placed in (or close to) the arc of the gate arms may trigger the CSS and keep the gates in a stopped position indefinitely, until the object is removed. To create an unobstructive store throughput the store manager should be informed that we recommended there should be no hand sanitizer units or baskets or any other displays etc. placed on the approaching walkway to the gate entry that would encourage the entering patron to “**stop**” before entering the store!

PCB Range Selection Chart.



| Setting | Range (cm) |
|----------|------------|
| 0 | 75 |
| 1 | 80 |
| 2 | 85 |
| 3 | 90 |
| 4 | 95 |
| 5 | 100 |
| 6 | 105 |
| 7 | 110 |
| 8 | 115 |
| 9 | 120 |
| A | 125 |
| B | 130 |
| C | 135 |
| D | 140 |
| E | 145 |
| F | 150 |

Select setting #5 initially to match the 1000mm arms & adjust up or down as required.
(See checklist for testing instructions and adjust to comply if required)

- C. PEC upright post sensors alignment: both green and yellow steady LED illumination should be on PEC board (see item 9 and below adjustment information.) when properly aligned.

Once PEC has been fully adjusted the main controller PCB the final time delay setting should be reset to 2 seconds delay (after gate reaches the stopped position count 2 seconds and the gate should start to **drive** home to the closed position again).

Adjustments

PEC must be powered up to begin with which will illuminate green light steadily.

Note: the brackets of the PEC sensors are spring loaded (see arrow in figure 6 below).

- The upper screw 1 is for trimming vertically.
- The lower screw 2 is for trimming horizontally.

Adjust **one** PEC at a time only by disconnecting the opposite PEC sensor unit temporarily until finished to ensure both PEC units are operating independently.

This PEC alignment/adjustment can be assisted by placing a piece of paper in the line of sight between the PEC and reflector which gives us a visual sighting of the red-light position needing to be aligned.

Note: if either of the PEC are not aligned correctly, the gates will stay open all the time!

Step A: adjust the lower screw 2 first to centralise the horizontal position red beam should be approx. in the centre position of the opposite reflector post then gently lock the screw (clockwise) hand tight.

Step B: now adjust the top screw 1 to adjust the PEC sensor vertically until the yellow light on top of sensor is steady (no flashing).

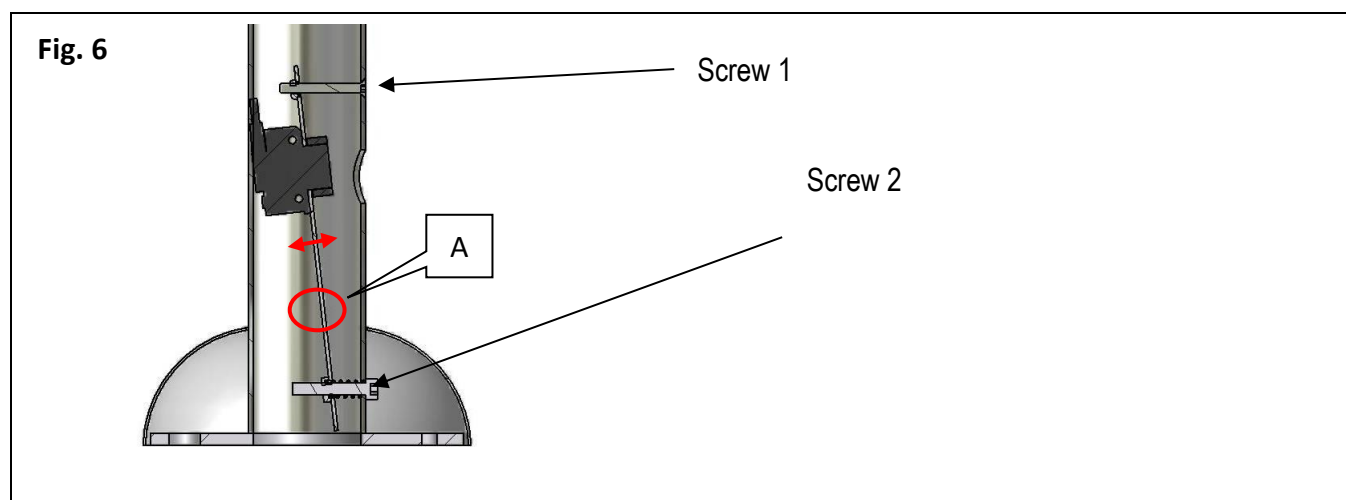

(When properly aligned both the green and yellow lights will be steadily illuminated continuously)

15. Woolworths's wiring configuration for gate arm LED colours:

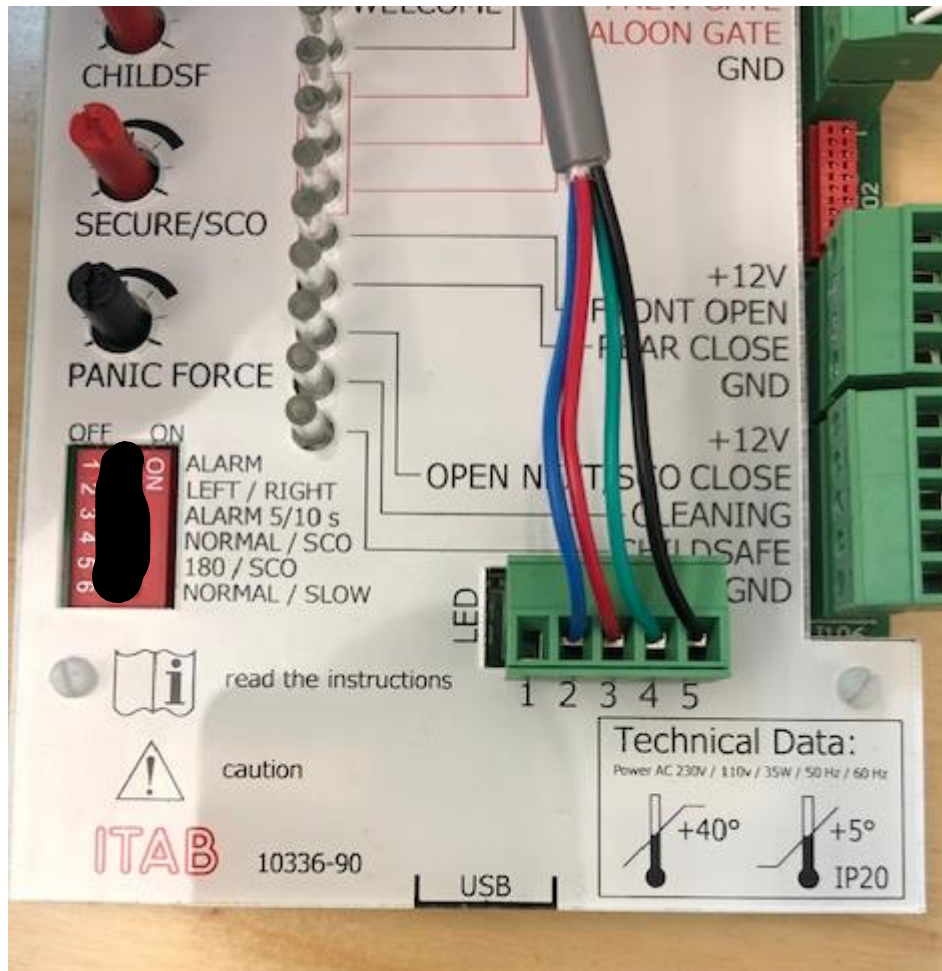

When connected as shown above the arms lights will operate to achieve the following LED colours for **Woolworths's** operations:

PCB LED wiring colours:

- 1 = not used
- 2 = blue
- 3 = red
- 4 = green
- 5 = black

- Gate in normal closed operation = green lighting illumination
- Gate while in moving operations = green lighting illumination
- Gate pushed into break out (wrong way) operations = red lighting flashing illumination

16. Gate arm assembly component breakdown.

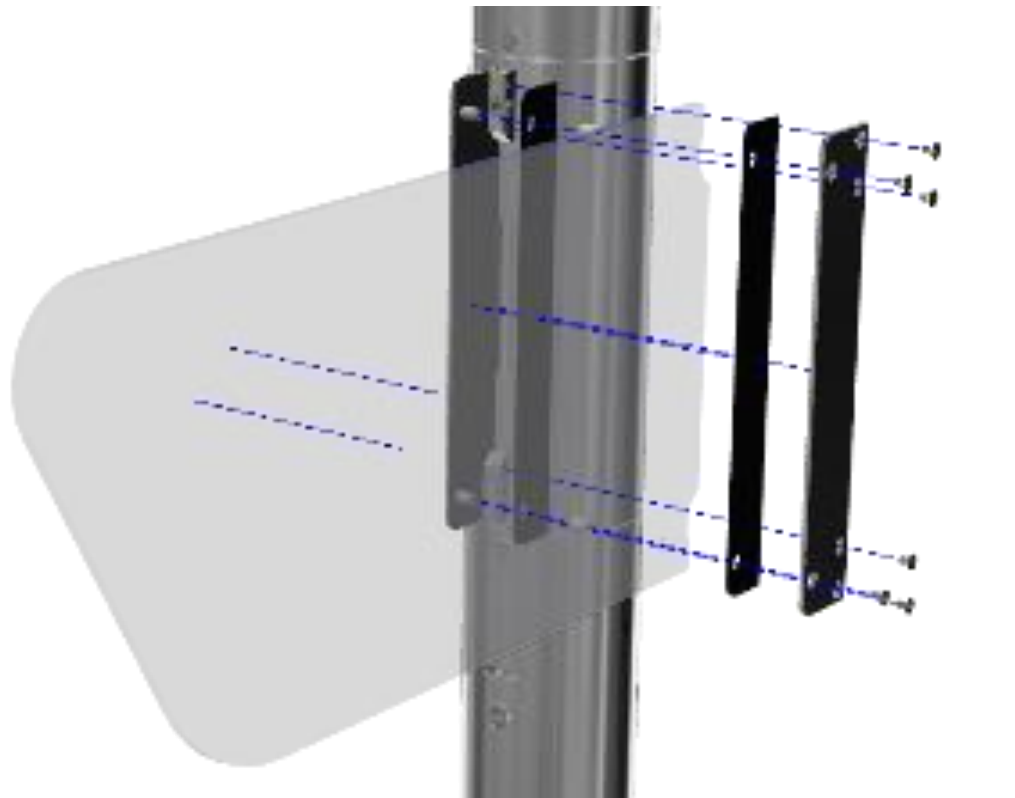

17. Approach radar triggering area box:

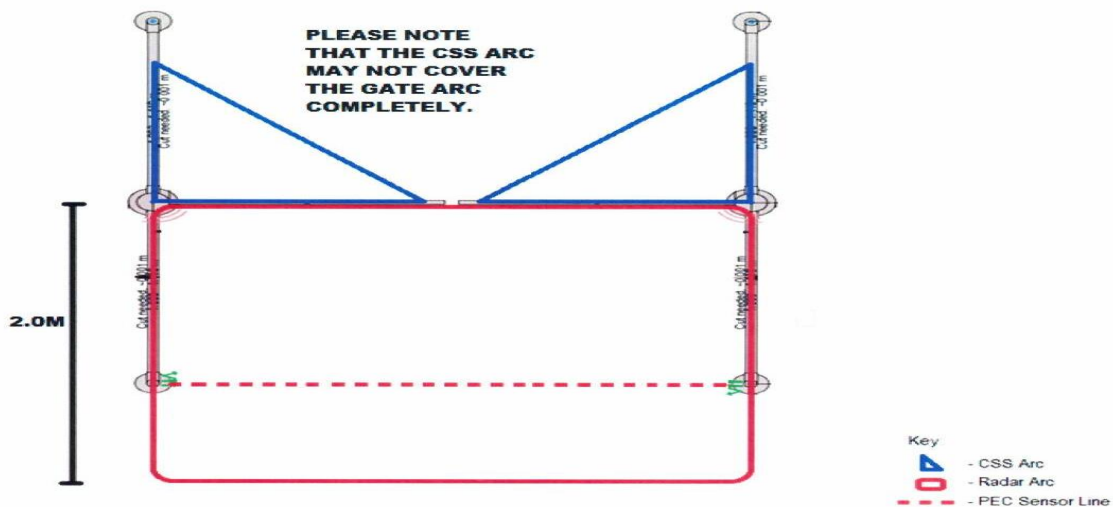

Complete the following quick tests:

- Blue markings behind the bollard (see image above) represents the pick-up area of the Child Safe Sensor (CSS). The alarm should sound when a person or object is within this blue area but **“only”** if the gate arms are in the fully closed position first – if the gate arms have started to open before a person or object enters this area the alarm will **not** usually sound – **test by stepping into the area.**
- Red markings in front of bollards represents the approach pick-up box of the radar approach sensor at 2m away. When a person steps into this approach area both gate bollards should immediately start driving into the store – note if either gate bollard have the CSS activated the radar will not trigger, therefor ensure the CSS arc is clear of any object or person during this test.

Test by placing an object in the area and **repeat the above test.**

- Radar adjustments should be made by checking radars trigger the gate bollard open within the 2m deep box (shown above) **without** the front PEC sensors in circuit. PEC upright post sensors should be tested **without** the Radar sensors in circuit to ensure they are successfully (independently of gate bollard radars) triggering the gates open when the signal is broken by an entering patron - **test by temporarily disconnecting the radar.**

18. Woolworths Itab entry gate arms orientation image:



19. Wiring link for audible alarm to trigger if gate arm arc has been penetrated:

Wire link to be terminated to OPEN NEXT/ SCO CLOSE & CHILDSAFE terminals.

Adding a cable link between OPEN NEXT/SCO CLOSE and CHILDSAFE will have the following effect on gate operation when the child safe sensor has been activated with the gates in the closed position.

- Child safe sensor will stop arm movement as normal
- Audible alarm now activates upon Child safe sensor activation
- Gate arms now flash red with alarm activation

Gates will flash red when the Child safe sensor has been activated while gates are in the open position as patrons enter the store. (please note audible alarm will not activate if gates have received an open trigger from radar sensors)

This function allows for the following: Patrons will be alerted not to exit via the welcome gates.

Staff will be alerted to objects being placed within Child safe zone

Delivers a clear indication of Child safe sensor activation

Please see photo indicating where wire link must be placed to achieve this function within the Child safe block connector located on the main PCB

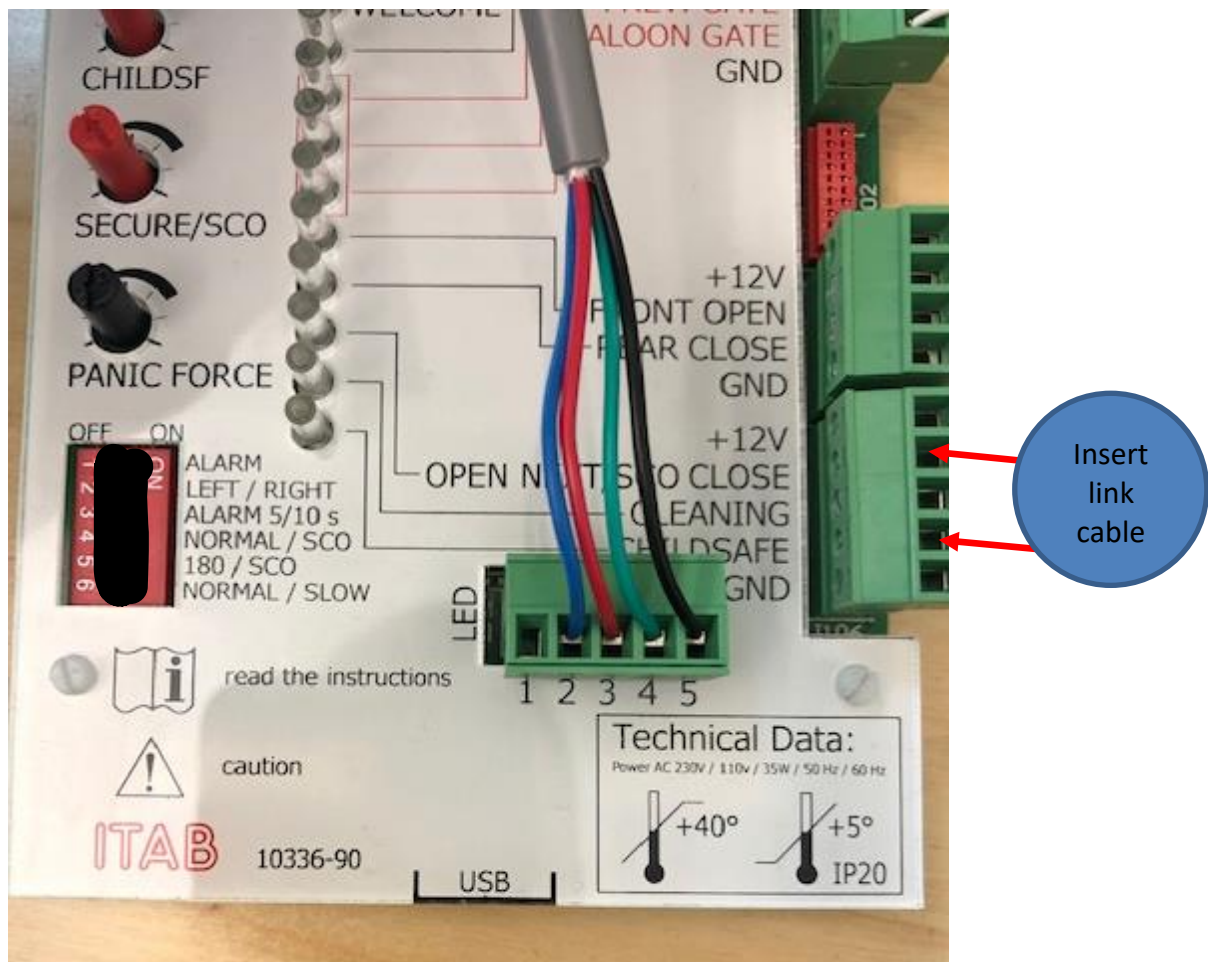

Item 20.

| Woolworths Itab autogates K7 (Phase 3) installation checklist & sign off document (D. Casey July 12, 2021) | | | |
|---|----------|---------|-----------------|
| Complete the following check list when installation is complete: | ✓ Yes | X No | Manual Check |
| Site manager to check that gates are fully operational by ticking the boxes and signing below: | | | (Ref. item #) |
| Are final layout dimensions compliant, as per below drawing - measure gate layout? | | | Page 1 |
| Are all gate arm LED colours operating compliantly (green for normal closed and opening - red for breakout position)? | | | 15 |
| Are all audible alarms compliant (sounding when arm is pushed in or out) with emergency breakout ? | | | 11 |
| Are audible alarms tested so as both alarms sound for 10 seconds (select left position on dip switch 3)? | | | 11/19 |
| Are all gate bollard radars individually tested to trigger gates open at 2.0 meters away from gate arms? | | | 14 |
| Are jointly-operated gate bollard radars tested to trigger gates open from (approx. 2.1 x 2.0 meter approach box area)? | | | 14/17 |
| Are gates operating as a saloon pair (either radar should trigger both arms open together) at the same time? | | | 4/12 |
| Are gates operating as a saloon pair (gate arms should close together 2 seconds after resting in opened fully position)? | | | 4/12 |
| Are all gates tested for delay of closing gate (beyond 2 seconds) if patron is still in the gate arms opening arc.? | | | 14 |
| Are all gates tested to auto-reset after break out has occurred (test by pushing arms into the breakout position) ? | | | N/A |
| Are both gate bollards tested for strong resistance (adjustment from breakout force pot.) to avoid false alarming? | | | 12 |
| Are both gate bollards tested to identify to slow down for the approx. 10 degrees of opening arc.?) | | | N/A |
| Are all posts and cross rails aligned straight with gate bollards (stay within centre of guide rails at 90 degree to arms)? | | | N/A |
| Are there a minimum of 40 mm gap between gate arms when in the fully closed position? | | | Page 1 |
| Are gate arms straight and fully aligned (do adjustments to avoid damaging the gate) with each other? | | | 6 |
| Are all gate arm plastic spacers fitted into BOTH gate arms (4 in total)? | | | 5 |
| Are all gate arms fitted with fully in tact rubber gaskets separating the arms from metal brackets? | | | 5 |
| Are all gate arms fitted with all original matching fixing screws (24 in total)? | | | 16 |
| Are all gate bollards top covers fitted with original matching fixing screws (6 in total)? | | | N/A |
| Are all gate bollard front cover plates fitted with original matching fixing screws (4 in total)? | | | N/A |
| Are all gate bollard cups fitted with original matching grub screws ? | | | N/A |
| Are all upright posts fitted with original matching grub screws? | | | N/A |
| Page 1/4 | | | |

| Ensure the CSS units are operating correctly on both gate arms, independently: | ✓ | X | Manual |
|--|---|---|--------|
| Has the CSS been tested to ensure they prevent the arms from moving when someone steps into the gate arc signal? | | | Video |
| Has CSS been tested to ensure they do triggering signal does not overlap the other gate arms arc.? | | | Video |
| Has the CSS been tested to ensure they are not triggering before passing the bollards centre position on approach? | | | Video |
| Has the CSS been tested to ensure they are not triggering beyond the centre of the lead out rail? | | | Video |
| Has the CSS been tested to ensure they are not triggering when a box is placed close up against the lead out rails? | | | Video |
| Other items: | | | |
| Has key operation been demonstrated to store staff (in case staff needs to be isolated gate bollards to remain open)? | | | N/A |
| Has decommissioned equipment been handed back to site manager (technician to take photo) ? | | | N/A |
| Confirm the following photos and videos of the works have be sent to Woolworths with this checklist: | | | |
| Photos showing the gate open and closed from inside store ? | | | N/A |
| Photos showing the gate open and closed from outside store ? | | | N/A |
| Photos showing the gate panel alignment when in an open and closed position? | | | N/A |
| Photos showing the use of the gate arm, rubber gasgets , sleeve on both gate panels? | | | N/A |
| Photos showing the use of the plastic spacer on the gate panels? | | | N/A |
| Photos showing that there are no screws missing on the arm fixing brackets? | | | N/A |
| Videos validating gates operations: | | | N/A |
| Videos showing the gates operate when objects are placed against the railing on both sides? | | | N/A |
| Videos showing the blind spot in the centre of the gate area? | | | N/A |
| Videos showing that the front sensors are triggered at a distance of 2 M ? | | | N/A |
| Follow up works required: | | | |
| Are you satisfied that the finished works are compliant and the layout is suitable to perform its intended operations? | | | N/A |
| Are there ground work fixings follow up required? | | | N/A |
| Are there any screws or rubber/plastic bungs needing replacing? | | | N/A |
| Are there any covers needing replacing? | | | N/A |
| Are there any keys needed to be supplied to the store? | | | N/A |
| Is there any equipment left behind for Woolworths perusal (if yes please was the store manager notified of location)? | | | N/A |
| Page 2/4 | | | |

(Woolworths sign-off document)

Store name:
 Store address:
 Store number:
 Store managers name:
 Store managers signature:
 Date:
 Contractor company name:
 Technicians name:
 Technicians signature:
 Date:

Please make notes of any follow works required below:

| | | |
|--|--|--|
| | | |
| | | |
| | | |
| | | |
| | | |
| | | |
| | | |
| | | |
| | | |
| | | |
| | | |
| | | |
| | | |
| | | |
| | | |
| | | |
| | | |
| | | |
| | | |
| | | |
| | | |
| | | |
| | | |
| | | |
| | | |
| | | |
| | | |
| | | |
| | | |

Page 3/4

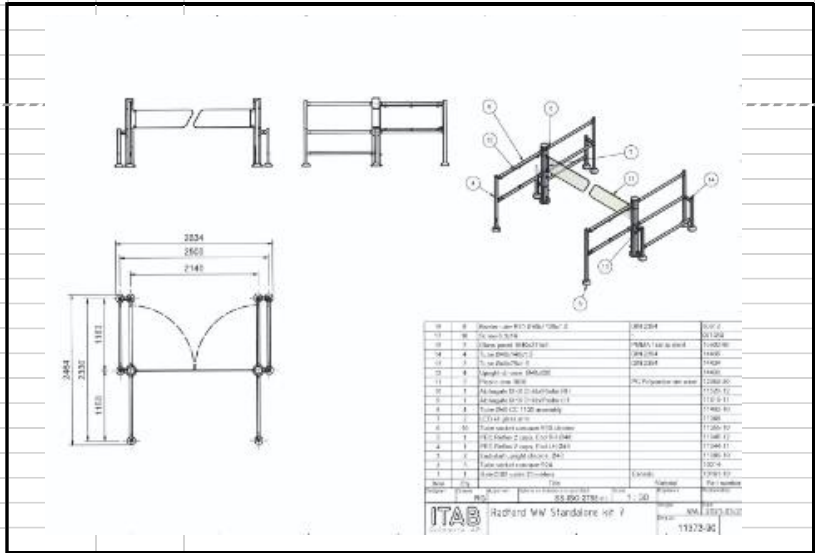

Woolworths K7 (phase 3 layout) autogate layout (prepared by D. Casey C/o Radford Retail Solutions P/L)

Page 4/4

Item 21.

Sensor adjustments video QR code.

